



ITS 96

Concealed
cam-action
door closer system

available in the US through

index-dTM 877-777-0592
www.index-d.com

Concealed cam-action door closer system DORMA ITS 96

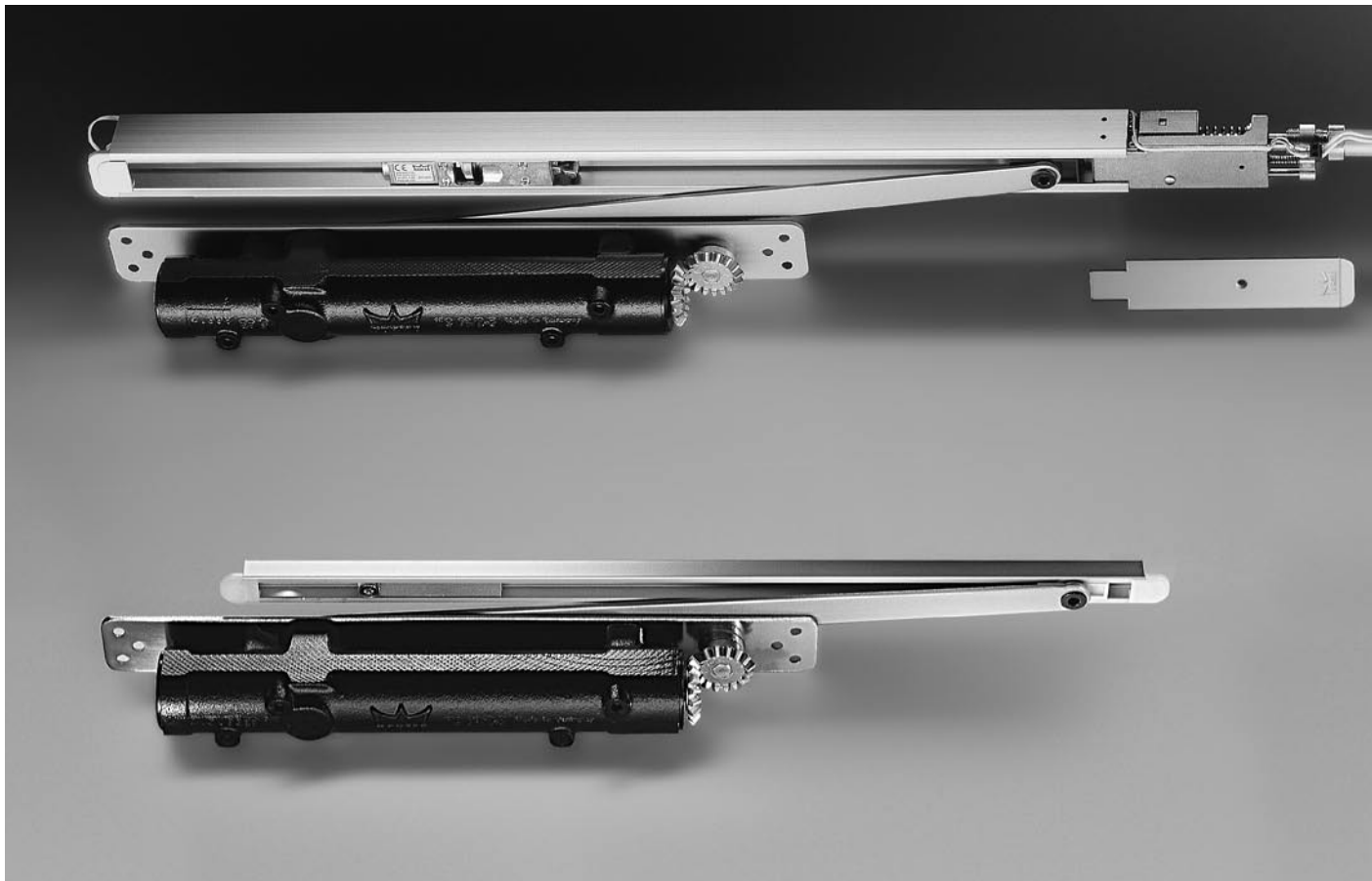

Flawless beauty

To ensure that prestigious doors retain all their inherent attraction, they can now be fitted with a concealed cam-action door closer system – the DORMA ITS 96. This is the first system of its kind, one which can be integrated in the door leaf and frame with the utmost elegance. Where the emphasis is on appearance, the disappearing DORMA System ITS 96 is the ideal solution for your doors: Advanced technology accommodated within the tightest of spaces, totally out of sight and featuring the proven heart-shaped cam which characterises all DORMA

slide channel door closers. The cam is literally at the heart of DORMA slide channel door closers – it guarantees secure closing while at the same time offering a rapidly decreasing opening force so that even children, the elderly and disabled people encounter only minimum resistance as they open the door. However, it is not only these categories of user who benefit. Thanks to the substantial reduction in effort required, this technology offers the ultimate in user convenience to all.

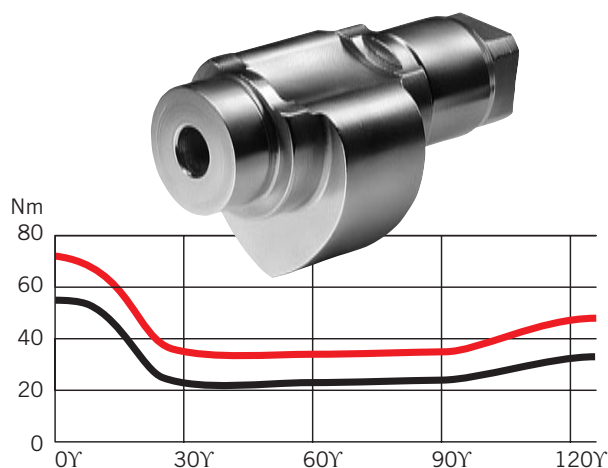

Force profile of an ITS 96 cam action door closer (Size EN 3 – 6, max. closing strength setting)

— Opening force
— Closing force

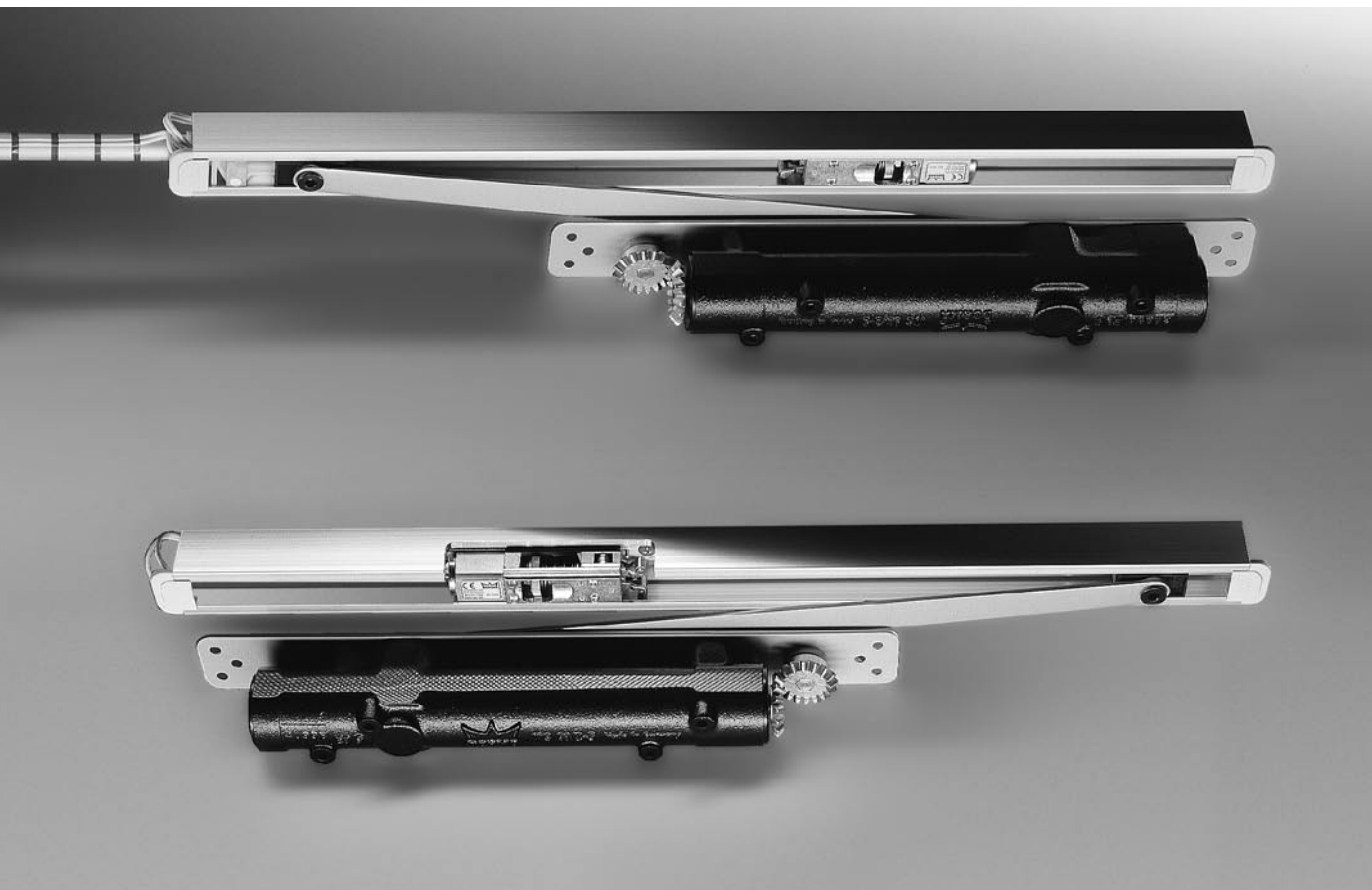

This CD-ROM contains the necessary information concerning DORMA ITS 96 System. Orders for the CD-ROM can be placed online under www.dorma.com

Contents	
	Page
DORMA ITS 96	
Features and functions	4
DORMA ITS 96	
Application and installation	6
DORMA G 96 N20	
Standard slide channel design	8
DORMA RF	
Hold-open unit	8
DORMA G 96 EMF	
Slide channel with electro-mechanical hold-open	10
DORMA G 96 GSR	
Slide channel door co-ordinator	12
DORMA G 96 GSR-EMF	
Slide channel door co-ordinator with electro-mechanical hold-open	14
DORMA RMZ, DORMA RM	
Frame-mounted and ceiling-mounted smoke detectors	20
Accessories	22
Hold-open systems	
Regulations and information	25
Range of equipment and optional accessories	26

Uncompromising technical sophistication

The DORMA ITS 96 has ushered in a new era in door closer technology. The closer body and slide channel are so compact that they can be installed out of sight in doors and their frames. These devices offer the same high quality expected of DORMA door closers, as characterised by their ease of operation for the user, and wide range of functions.

Thanks to the exceptionally slender dimensions of the unit, the DORMA ITS 96 can be installed in virtually all doors with thicknesses of 40 mm or more, and offers all the advantages of quality assured manufacture with third-party auditing.

Certified to ISO 9001.

Plus points...

...for the trade

- Low inventory costs and reduced stocking requirements thanks to streamlined modular system and separate packaging of closer body and slide channel assemblies.
- Tailor-made applications with special accessories.

...for the installer

- Non-handed system.
- Can be incorporated within the door pre-fabrication process, allowing complete installation in the factory.
- Easy adjustment of the closing strength, closing speed and latch action after hanging of the doors.

...for the specifier/architect

- Unblemished appearance of prestige doors thanks to concealed installation.
- Ideal for doors integral to the interior design.

...for the user

- Optimum protection against vandalism thanks to the concealed installation.
- Enhanced user convenience and fully controlled, reliable closing with adjustable latch action.
- Cushioned limit stay with progressive damping for protection of wall and door.



Data and features		ITS 96	
Variable closing force	Spring strength	EN 2-4	EN 3-6
Standard doors	up to 1100 mm up to 1400 mm	●	●
External doors, outward opening		-	-
Fire and smoke check doors	up to 1100 mm up to 1400 mm	●	●
Door leaf thickness	equal to/greater than 40 mm equal to/greater than 50 mm	●	-
Max. door leaf weight in kg		100	180
Non-handed design (closer)		●	●
Arm	Slide channel	●	●
Closing force variable by means of adjustable screw		●	●
Closing speed adjustable by means of valve		●	●
Latching speed adjustable by means of valve		●	●
Cushioned limit stay, mechanical		●	●
Delayed action		-	-
Hold-open		○	○
Max. door opening angle (depends on door design)		approx. 120°	
Weight in kg		1.3	2.5
Dimensions in mm	Length Width Height	277 32 42	291 39.5 51
Door closer tested to EN 1154 A		●	
Hold-open devices tested to EN 1155		●	
Door co-ordinators tested to EN 1158		●	
CE mark for building products		●	

● Yes - No ○ Option

Further information

Additional information about many of our products is available from a range of electronic media (Internet, CD-ROM, diskettes). The abbreviated codes next to the computer symbol  indicate the search terms.

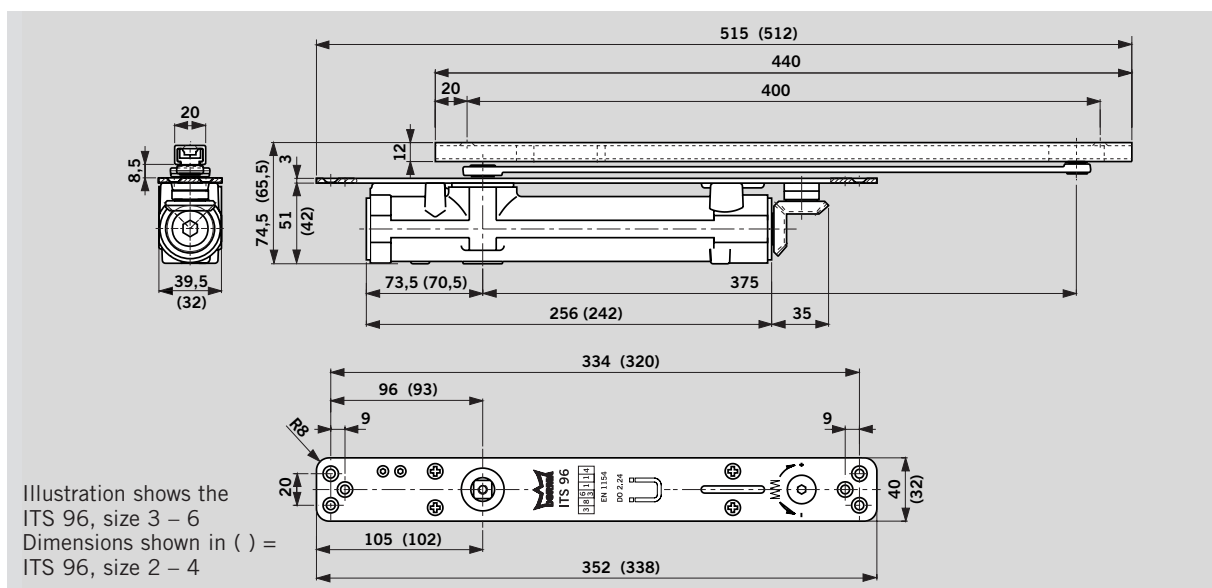

Adjustment of settings

The functions of the DORMA ITS 96 can be individually adapted to the local conditions of each application. The closing strength can be easily varied in accordance with the door width via the adjustment screw accessible from the top. The closing speed and the latch action can likewise be modified at any time using adjustment screws at the top, even after the door has been hung.

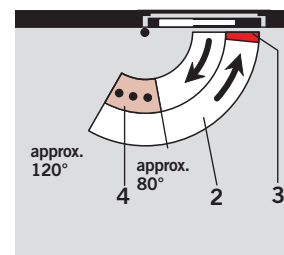
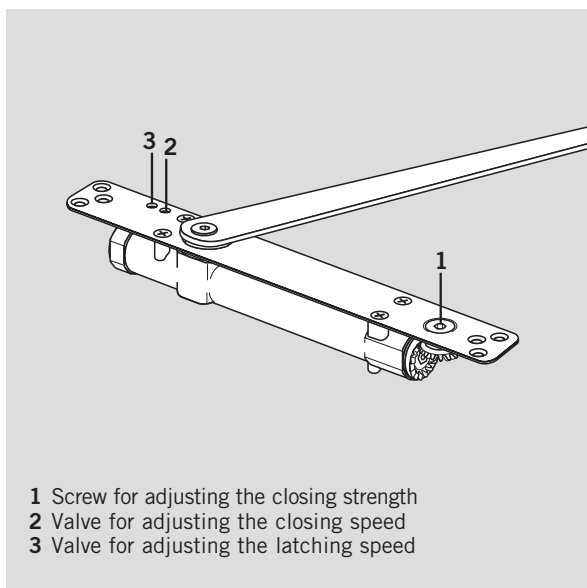

- 2 Fully controlled closing with adjustable speed
- 3 Adjustable latch action
- 4 Cushioned limit stay

Cushioned limit stay

The integrated mechanically cushioned limit stay of the DORMA ITS 96 is progressively damped to protect the wall and doors from the damage arising from the door being opened too wide (under conditions of normal usage). It can be adjusted to an opening angle between approx. 80° and max. 120°. **The cushioned limit stay feature is not an overload protection device and in many cases cannot replace a doorstop.**

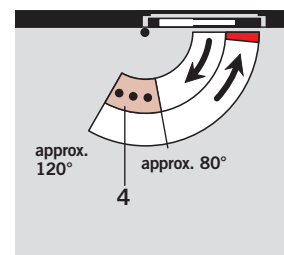
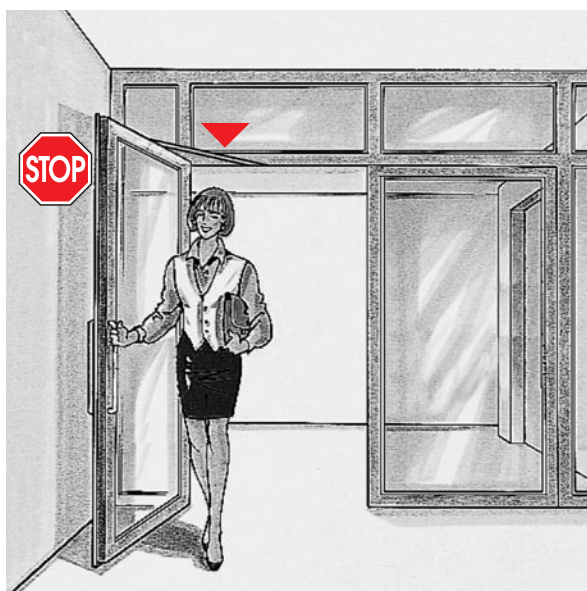

- 4 Cushioned limit stay

F Approval certification

The DORMA ITS 96 is approved by the State Material Testing Authority, Dortmund, in accordance with EN 1154 A. Additionally, the model size EN 2 – 4 and EN 3 – 6 has CERTIFIRE approval for use on timber FD30 and FD60 doors (code ITT), when installed with the approved intumescent gasket set for FD30 or FD60 supplied by DORMA UK. The length, width and height of mortice for the body and slide channel must be increased by 2 mm to accommodate the gasket.

Specification text

Cam-action door closer integrated in the door leaf or frame, tested to EN 1154 A, with rapidly decreasing opening torque/force. Closing strength, closing speed and latch action adjustable. Non-handed, with slide channel... (see pages 8 – 15)

Size
 EN 2 – 4
 EN 3 – 6

Make DORMA ITS 96

 ITS96/2-4
 ITS96/3-6



available in the US through

index-d 877-777-0592
 www.index-d.com

The DORMA ITS 96 concealed cam action door closer system is suitable for various door designs and different rebate clearance dimensions. This is achieved through the combination of different spindle lengths

available with the closer and the universal K8/K12 slide channel. Installation suggestions for the DORMA ITS 96 door closer system relating to the most common door types are available from DORMA on request.

G 96 N20
G 96 EMF
G 96 GSR/GSR-EMF

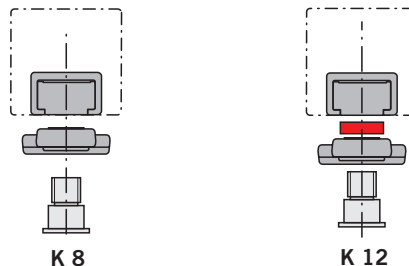

ITS 96 2-4
ITS 96 3-6

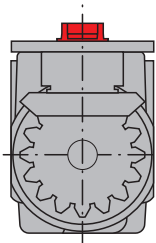

ITS 96 2-4
ITS 96 3-6
with 4 mm
extended spindle

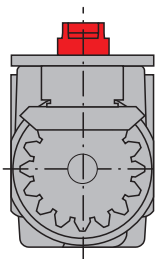

ITS 96 2-4
ITS 96 3-6
with 8 mm
extended spindle

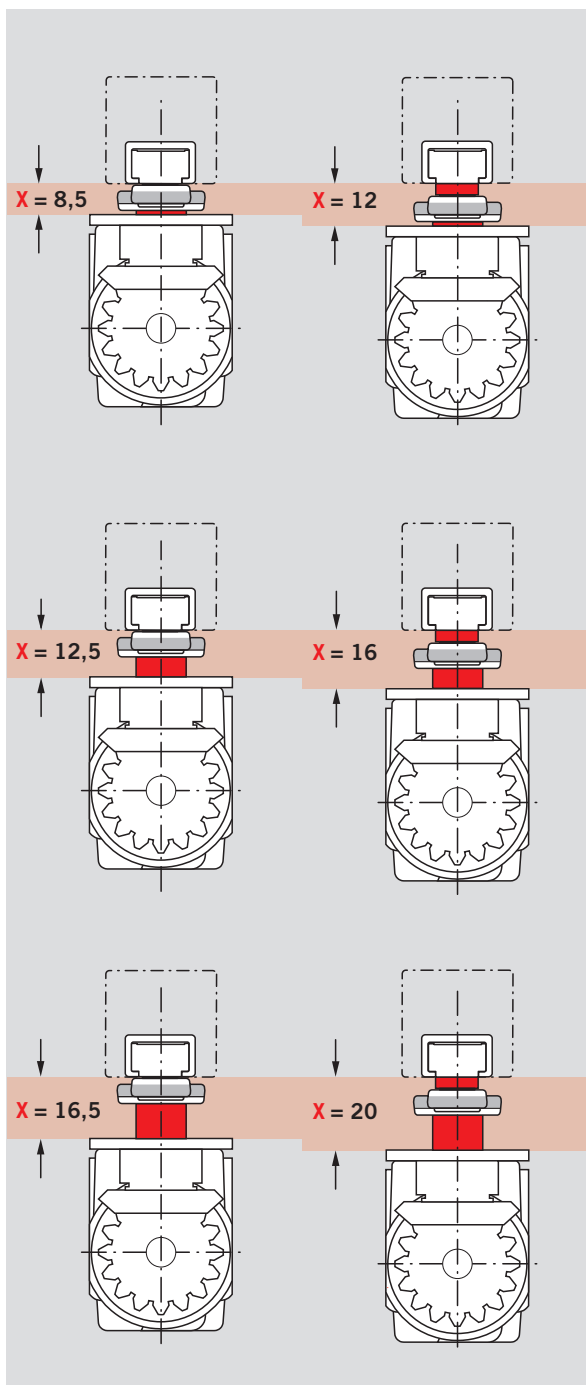
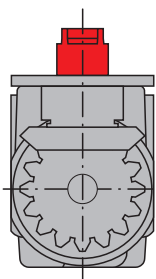

Timber door, flush-closing, clearance 8.5 mm, with ITS 96 EN 3-6 and slide channel G 96 N20 K8.

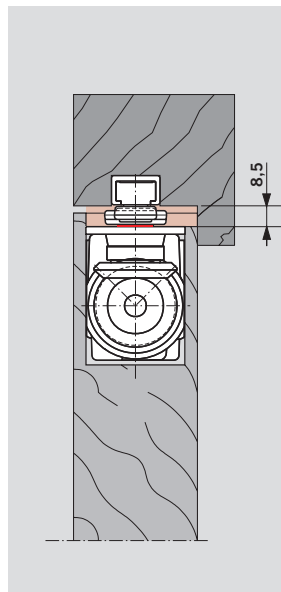

Timber door with steel frame, flush closing, clearance 12.5 mm, with ITS 96 EN 3-6, 4 mm extended spindle and slide channel G 96 N20 K8.

 Please check dimensions carefully

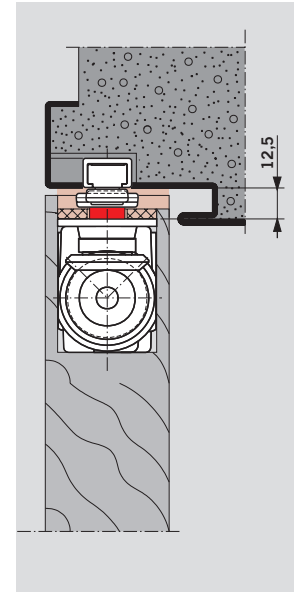

Tubular steel frame door, flush-closing, clearance 12 mm, with ITS 96 EN 3-6 and slide channel G 96 N20 K12.

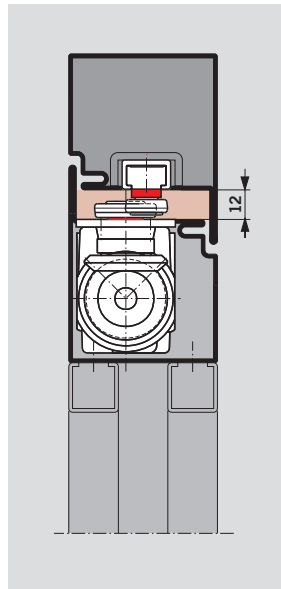

Aluminium tubular frame door, flush-closing, clearance 16 mm, with ITS 96 EN 3-6, 4 mm extended spindle and slide channel G 96 N20 K12.

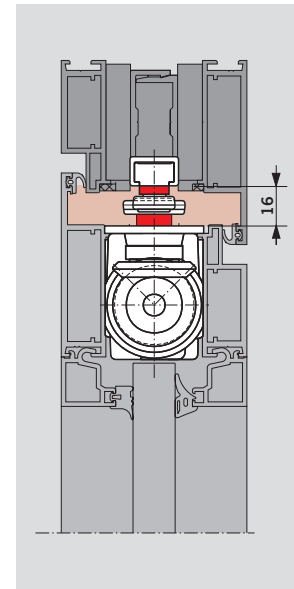

Hollow steel door with steel frame, over-rebated, clearance 12 mm, with ITS 96 EN 3-6, 4 mm extended spindle and slide channel G 96 EMF K8.

 Please check dimensions carefully

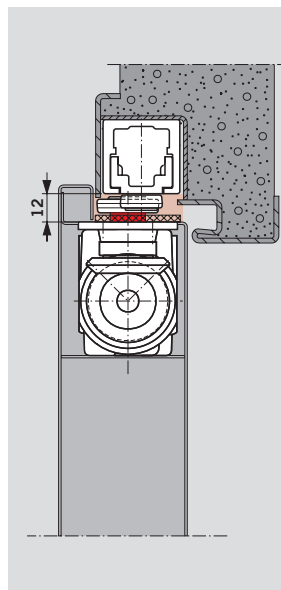

Timber door with solid frame, double rebated, clearance 20 mm, with ITS 96 EN 3-6, 8 mm extended spindle and slide channel G 96 N20 K12.

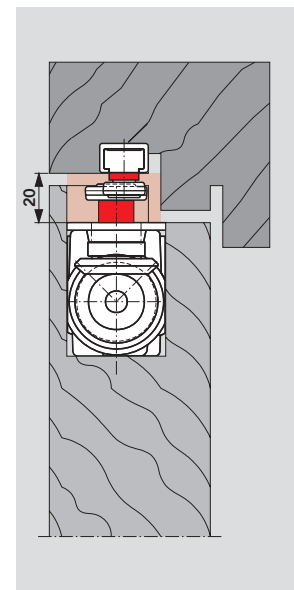

Standard model

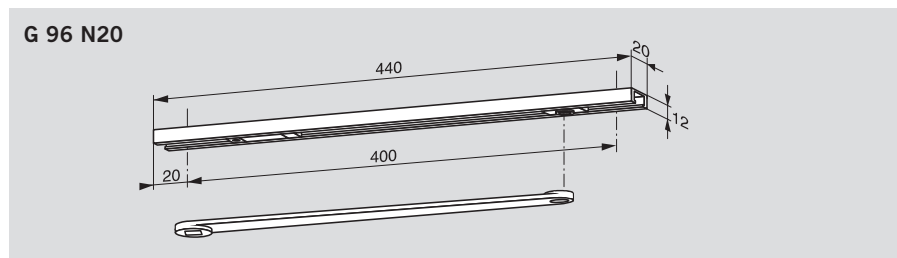

The **DORMA G 96 N20** slide channel pack includes the arm, slide channel, slide block, cushioned limit stay and fixing screws, and can be combined with both door closer sizes in the DORMA ITS 96 range.

The DORMA G 96 N20 slide channel is adjustable to K8/K12.

F Approval certification

The G 96 N20 slide channel is tested to EN 1154 A in conjunction with the DORMA ITS 96. Additionally, it has CERTIFIRE approval for use on timber FD30 and FD60 doors (code ITT), when installed with the approved intumescent gasket set for FD30 or FD60 supplied by DORMA UK. The length, width and height of mortice for the slide channel must be increased by 2 mm to accommodate the gasket.

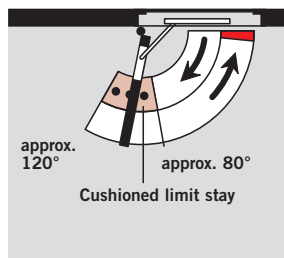

Specification text

DORMA ITS 96 ... door closer (see pages 4 and 5) with slide channel G 96 N20

Version

- LH (ISO 6) K8/K12
- RH (ISO 5) K8/K12

Make DORMA ITS 96 N20

- ITS96/2-4
- ITS96/3-6

Hold-open unit

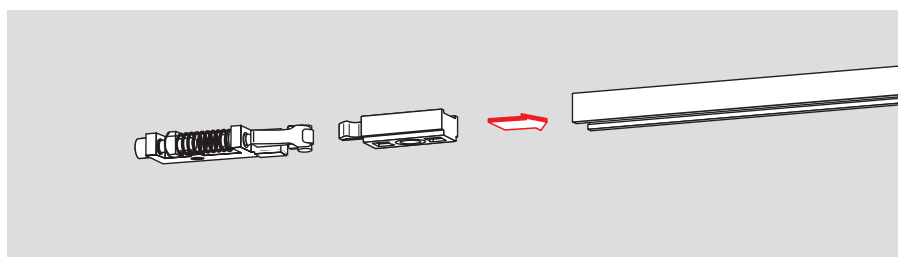

The **DORMA RF** hold-open unit enables doors to be securely held without any fall-back at precisely the required position up to an opening angle of approx. 120°. The pull-off force can be adjusted to any door situation. The DORMA RF

mechanism is non-handed and has been specifically designed for retrofitting to the G 96 N20 slide channel.

Not for fire and smoke check doors.

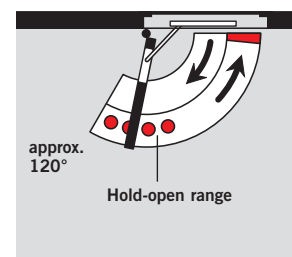

Accessories

- Hold-open unit DORMA RF G 96 N20
- ITS96RF/2-4
- ITS96RF/3-6

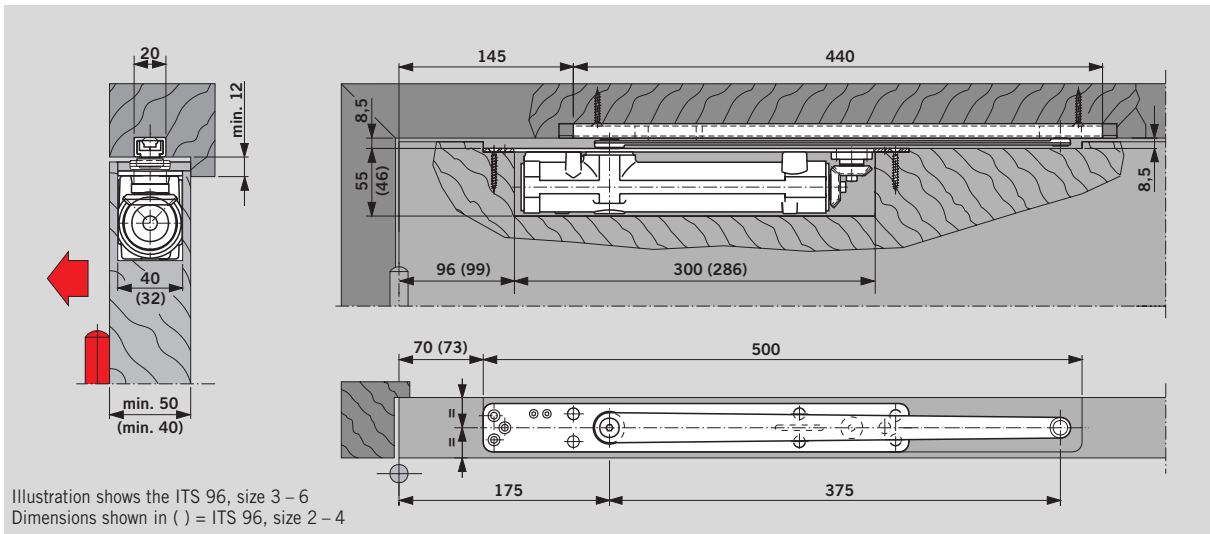

DORMA ITS 96 door closer with DORMA G 96 N20 slide channel in a **timber door**
Example: Anticlockwise-closing (ISO 6) door; mirror image applies to clockwise-closing (ISO 5) doors.

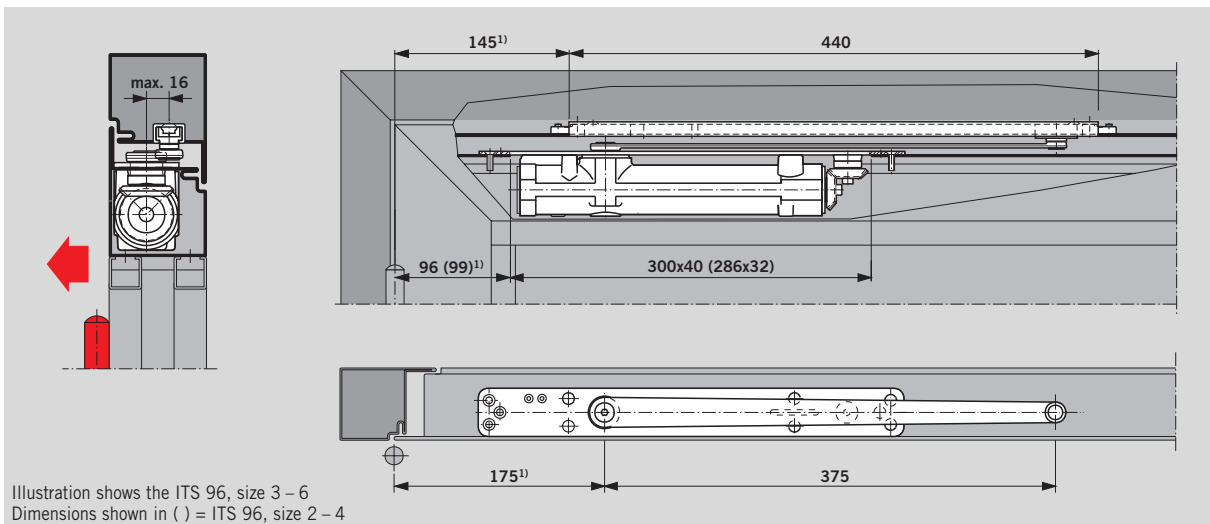

DORMA ITS 96 door closer with DORMA G 96 N20 slide channel in an **aluminium framed door**
Example: Anticlockwise-closing (ISO 6) door; mirror image applies to clockwise-closing (ISO 5) doors.
¹⁾Add 25 mm for aluminium profile frames with corner-angle reinforcement.

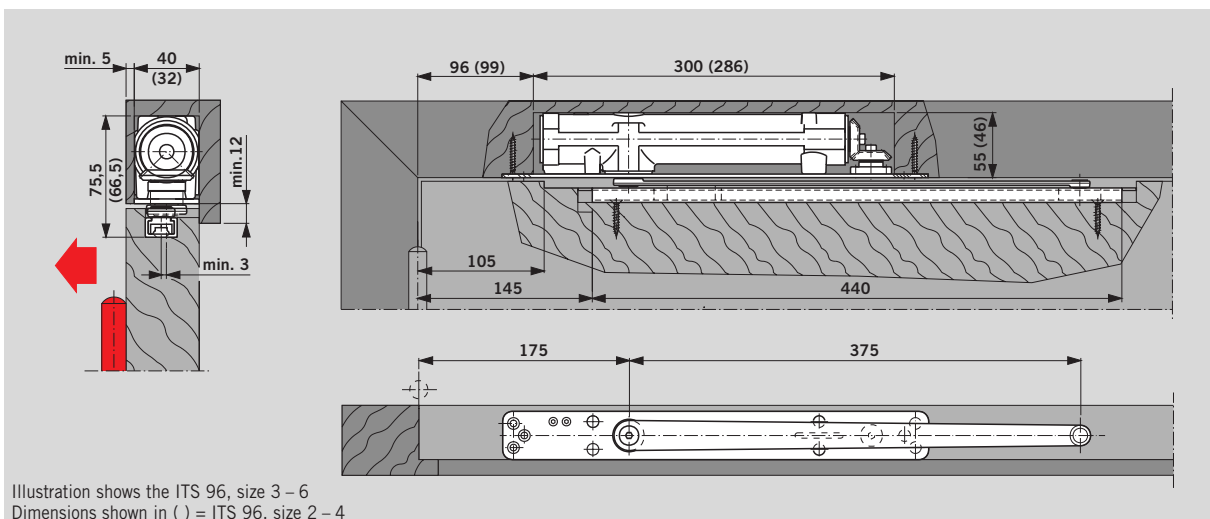

DORMA ITS 96 door closer with DORMA G 96 N20 slide channel in a **timber door-transom fixing**
Example: Anticlockwise-closing (ISO 6) door; mirror image applies to clockwise-closing (ISO 5) doors.

Electro-mechanical hold-open

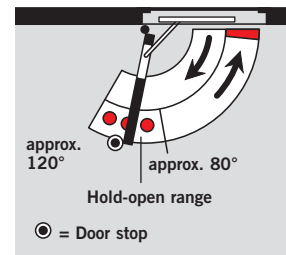
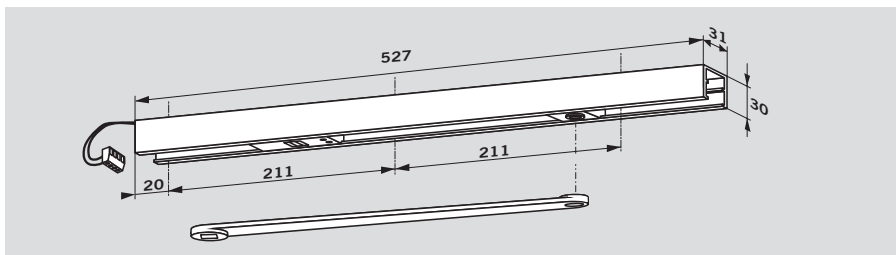

The **DORMA G 96 EMF** slide channel assembly enables the door to be held open securely at a pre-selected position without fall-back. The hold-open point can be adjusted within an opening angle of approx. 80° and 120°.

Note:

The hold-open point also constitutes the max. door opening angle (position door stop accordingly).

In the event of an alarm or a fault in the power supply, the hold-open is released and the door is closed by the door closer. The release is triggered by a signal from external smoke detectors (e.g. DORMA RMZ). The release force for the hold-open mechanism can be adjusted without tools and is rated to ensure that the door can also be easily released manually.

The DORMA G 96 EMF slide channel assembly comprises the arm, slide channel, slide block, electro-mechanical hold-open unit and fixing screws, and can be combined with both door closer sizes in the DORMA ITS 96 range. In the case of particularly large and heavy doors (over 1250 mm), we recommend that DORMA EM hold-open magnets be employed instead of the electro-mechanical hold-open unit.

Specification text

DORMA ITS 96 ... door closer (see pages 4 and 5) with G 96 EMF K8/K12 slide channel assembly, with integrated 24 V DC electro-mechanical hold-open, tested to EN 1155. Hold-open point (80° – 120°) and release force adjustable. Approved by the Institute for Building Technology, Berlin, for general use in hold-open systems. Acceptance inspection of the system is mandatory in Germany.

Technical data	
Operating voltage:	24 V DC, ± 15%
Power input:	1.4 W
Rated for continuous duty:	100%
Release force:	Adjustable

Version

- LH (ISO 6) K8/K12
- RH (ISO 5) K8/K12

Make DORMA ITS 96 EMF

- ITS96EMF/2-4
- ITS96EMF/3-6

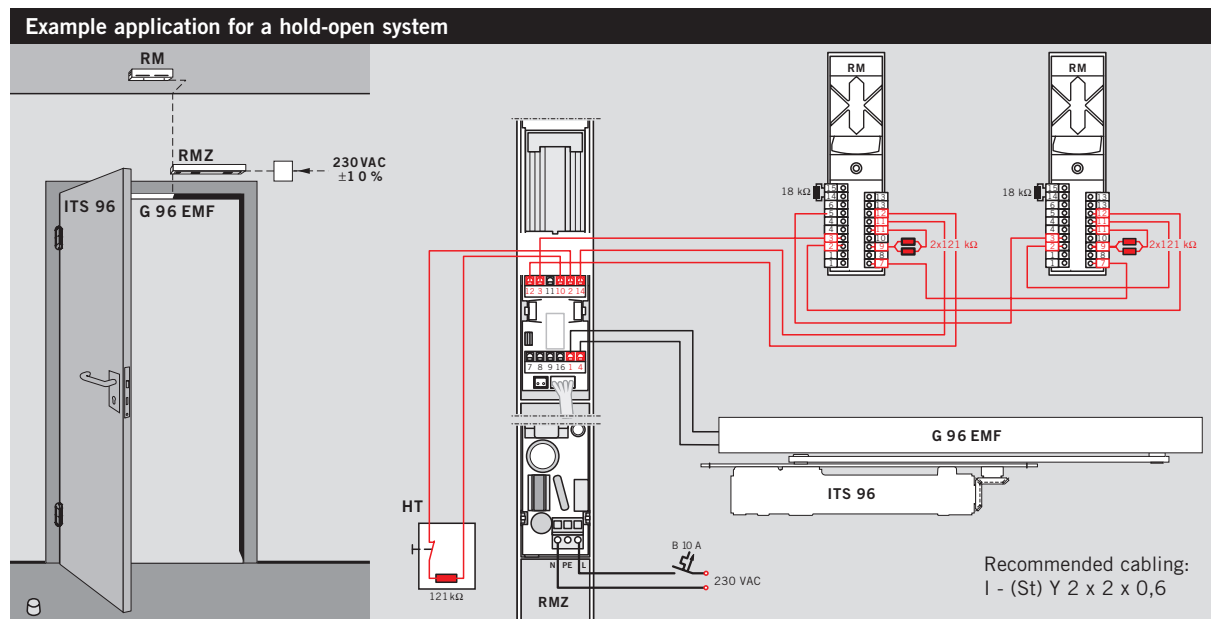

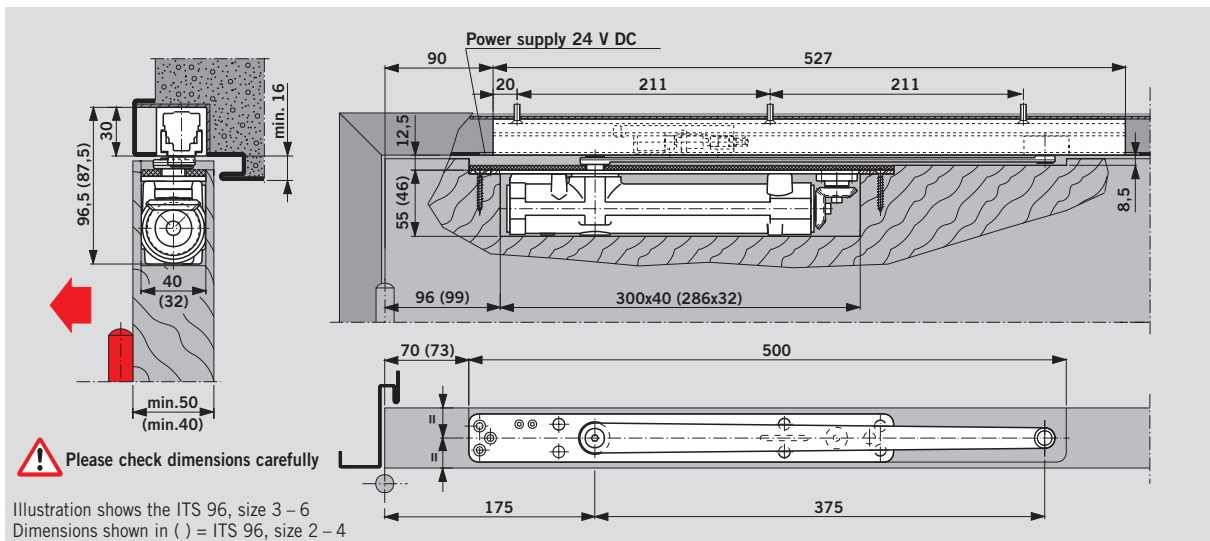

DORMA ITS 96 door closer with DORMA G 96 EMF slide channel assembly in a **timber door**
Example: Anticlockwise-closing (ISO 6) door; mirror image applies to clockwise-closing (ISO 5) doors.

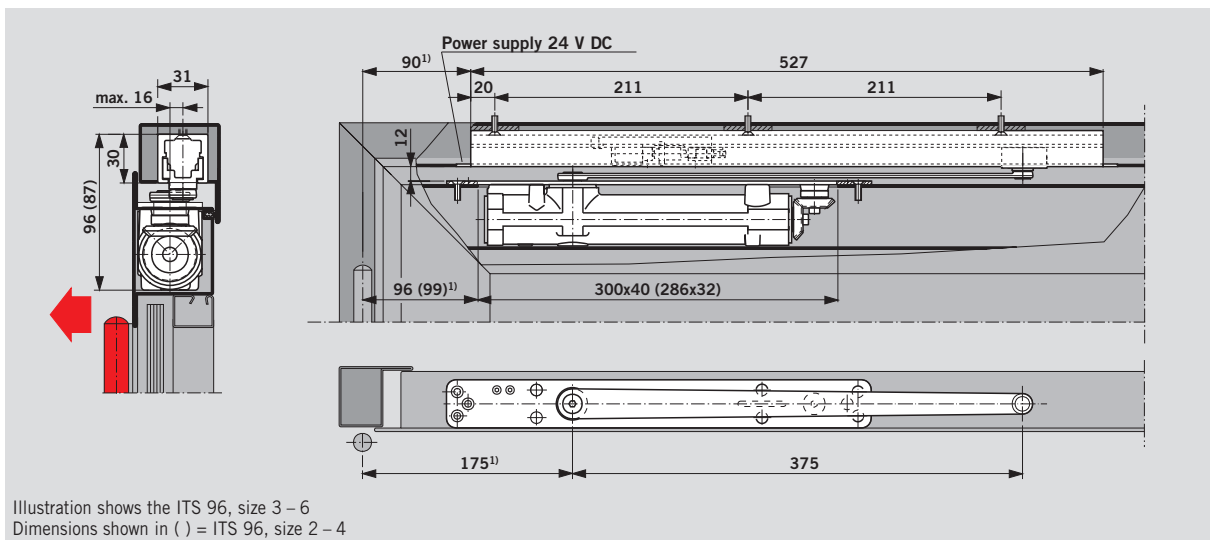

DORMA ITS 96 door closer with DORMA G 96 EMF slide channel assembly in an **aluminium framed door**
Example: Anticlockwise-closing (ISO 6) door; mirror image applies to clockwise-closing (ISO 5) doors.
¹⁾Add 25 mm for aluminium profile frames with corner-angle reinforcement.

F Approval certification

The DORMA ITS 96 EMF has been tested by the State Material Testing Authority, Dortmund, to EN 1155, Electrically Powered Hold-open Devices.

Regulations/Information

The use of hold-open devices may be subject to certain conditions – see page 25.

Door co-ordinator

The **DORMA G 96 GSR** slide channel with integral door co-ordinator for pairs of doors ensures that the active leaf always closes after the inactive leaf.

The DORMA G 96 GSR slide channel door co-ordinator features a push rod clamping system. As this system operates independently of door closer hydraulics, it offers maximum safety and reliability.

An overload release protects the door co-ordinator and the door set from damage. The DORMA G 96 GSR can be combined with both door closer sizes of the DORMA ITS 96 range.

Version/Function	Door width (mm)	Door leaf thickness min. (mm)	Closer size ITS 96
GSR Door co-ordinator	1400 – 2200	40	2 – 4
	1400 – 2800	50	3 – 6

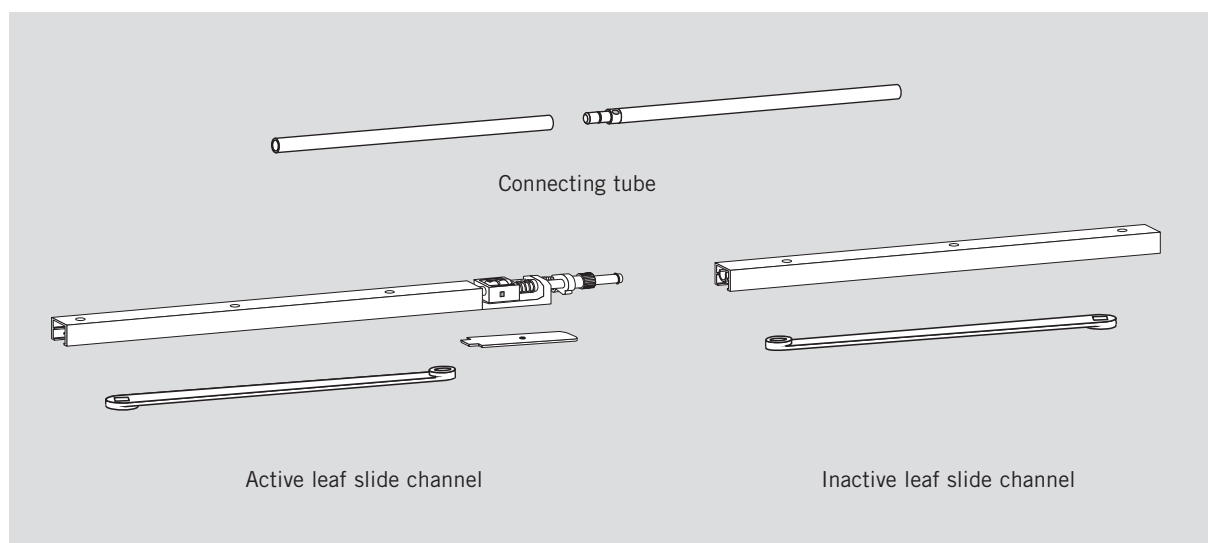

A DORMA G 96 GSR slide channel door co-ordinator encompasses an active leaf and an inactive leaf slide channel with cushioned limit stay, a connecting tube, a cover for the co-ordinator mechanism on the active leaf slide channel, and two arms.

F Approval certification

The DORMA ITS 96 GSR has been tested to EN 1158, Door Co-ordinator Devices by the State Material Testing Authority, Dortmund/Germany.

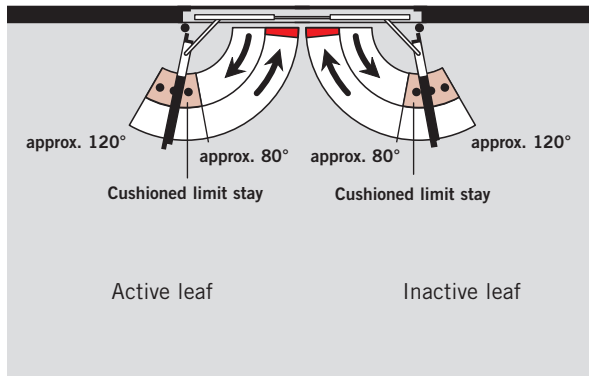

Specification text

DORMA ITS 96 ... door closer (see pages 4 – 5) with G 96 GSR K8/K12 slide channel, featuring integrated mechanical door co-ordinator using a push rod clamping system with overload release which operates independently of the closer hydraulics. Standard design – door leaves with no hold-open. Tested to EN 1158.

Approved by the Institute of Building Technology, Berlin, for general use in conjunction with fire and smoke check doors.

Make
DORMA ITS 96 GSR

 ITS96GSR/2-4
ITS96GSR/3-6

Example application

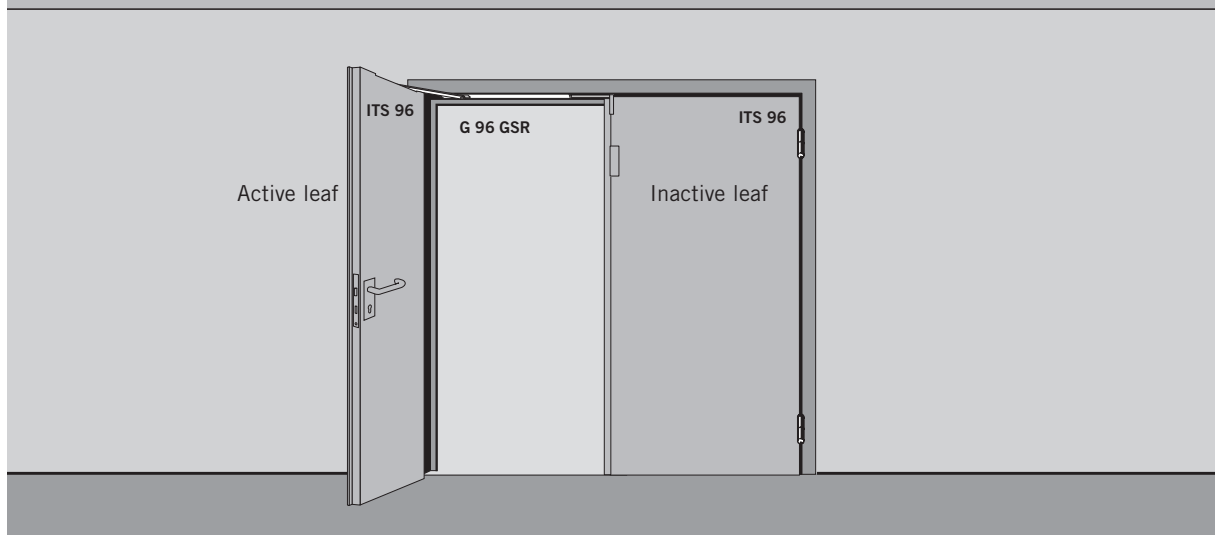

Door co-ordinator with electro-mechanical hold-open

This door co-ordinator not only ensures the correct closing sequence of pairs of doors, but also allows the door leaves to be individually held open by an electro-mechanical device. The hold-open point for both door leaves lies between approx. 80° and 120°.

Note:

The hold-open point also constitutes the max. door opening angle – position door stop accordingly.

In the event of an alarm or a fault in the power supply, the hold-open is released and the door is closed by the door closer. The release is initiated by a signal from external smoke detectors (e.g. DORMA RMZ) or other fire alarm.

The release force for the hold-open mechanism can be adjusted without tools and is rated to ensure that the door can also be easily released manually.

The DORMA G 96 GSR-EMF slide channel door co-ordinator can be combined with both door closer sizes of the DORMA ITS 96 range.

In the case of particularly large and heavy doors (over 2500 mm), we recommend that DORMA EM hold-open magnets be employed instead of the electro-mechanical hold-open unit.

Regulations/Information

The use of hold-open devices may be subject to certain conditions – see page 25.

Version/Function	Door width (mm)	Door leaf thickness min. (mm)	Closer size ITS 96
GSR-EMF Door-coordinator and hold-open in both leaves	1400 – 2200	40	2 – 4
	1400 – 2800	50	3 – 6

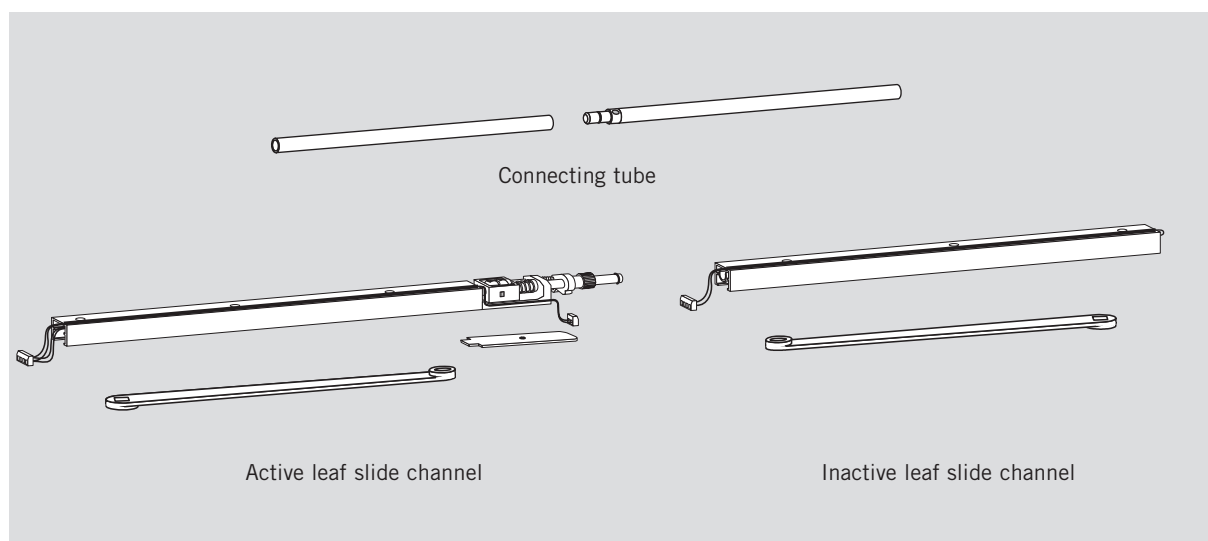

A DORMA G 96 GSR slide channel door co-ordinator encompasses an active leaf and an inactive leaf slide channel with electro-mechanical hold-open, a connecting tube, a cover for the co-ordinator mechanism on the active leaf slide channel, and two arms.

Technical data

Operating voltage:	24 V DC, ± 15%
Power input:	2.8 W
Rated for continuous duty:	100%
Release force:	Adjustable

F Approval certification

The DORMA ITS 96 GSR-EMF has been tested by the State Materials Testing Authority, Dortmund, to EN 1158, Door Co-ordinator Devices, and EN 1155, Electrically Powered Hold Open Devices.

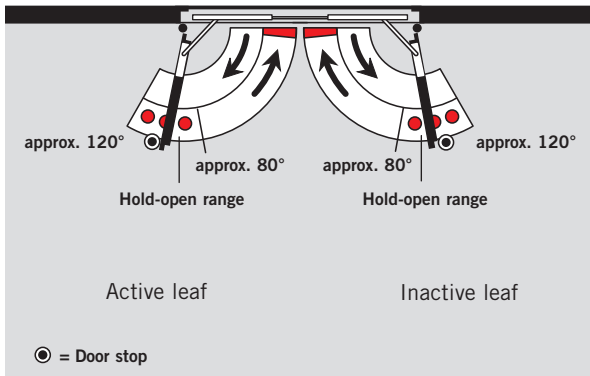

Specification text

DORMA ITS 96 ... door closer (see pages 4 – 5) with G 96 GSR-EMF K8/K12 slide channel, featuring integrated mechanical door co-ordinator using a push rod clamping system with overload release which operates independently of the closer hydraulics, with integrated electro-mechanical hold-open, 24 V DC. Hold-open point (80° – 120°) and release force adjustable. Tested to EN 1158 and EN 1155.

Approved by the Institute of Building Technology, Berlin, for general use in hold-open systems. Acceptance inspection of the system is mandatory in Germany.

Make
DORMA ITS96GSR-EMF

ITS96GSR-EMF/2-4
ITS96GSR-EMF/3-6

Example application, hold-open system

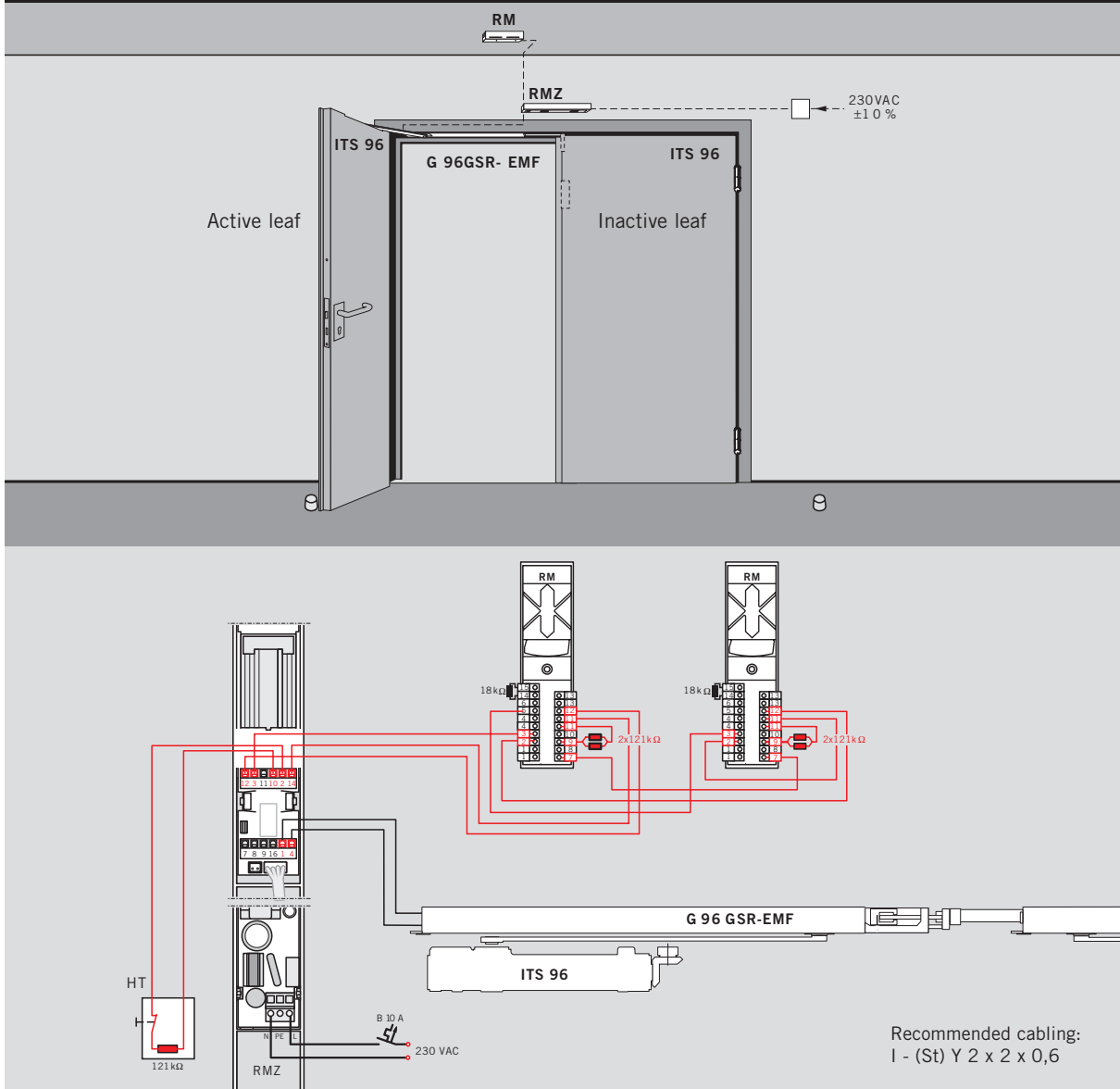

Installation in a timber door

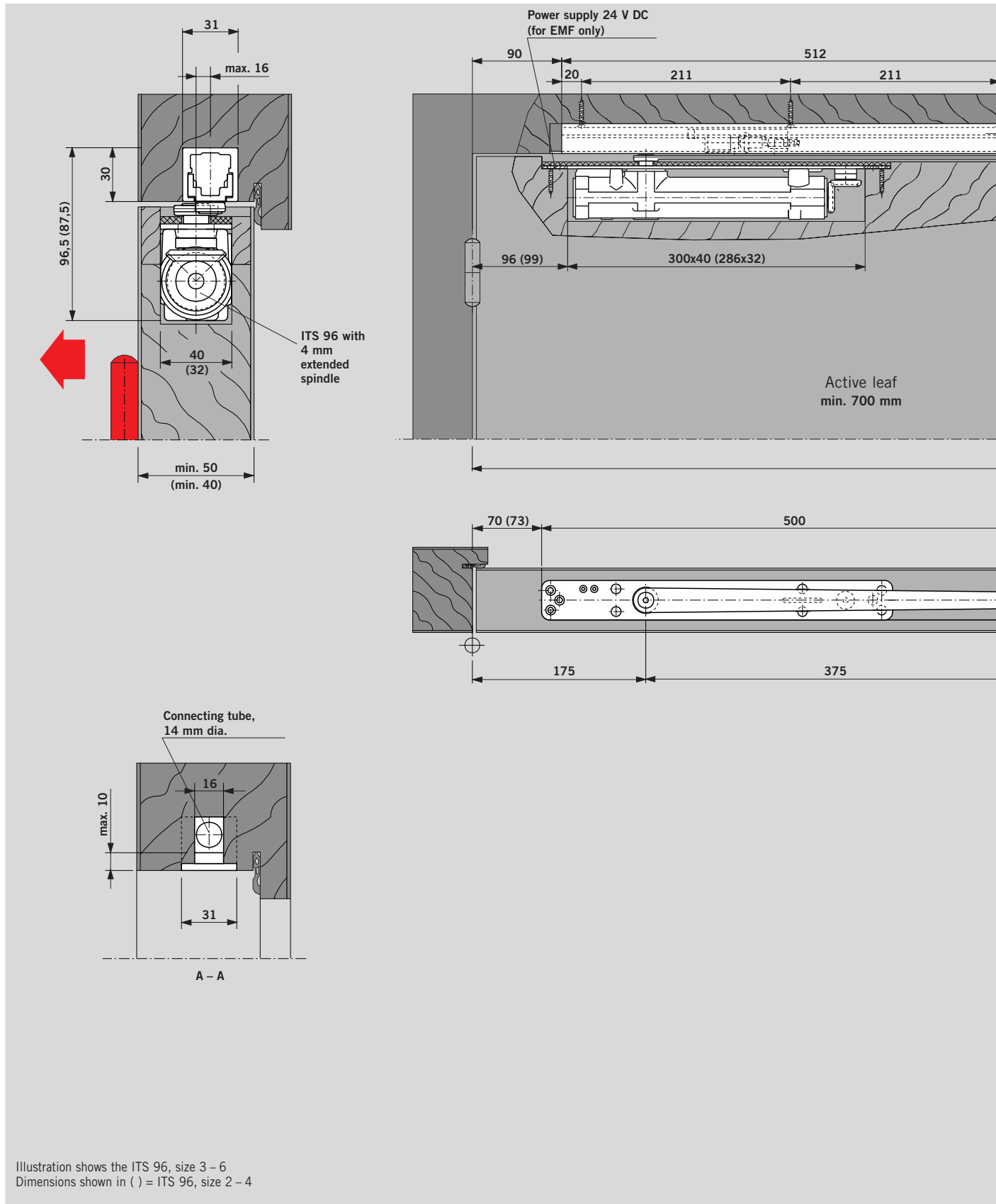

DORMA ITS 96 door closer with DORMA G 96 GSR/GSR-EMF slide channel
Example: Anticlockwise-closing (ISO 6) active leaf; mirror image applies to clockwise-closing (ISO 5) active leaf.

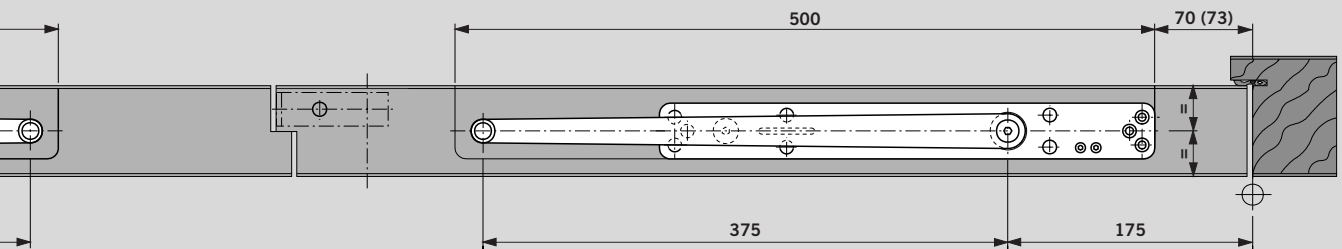
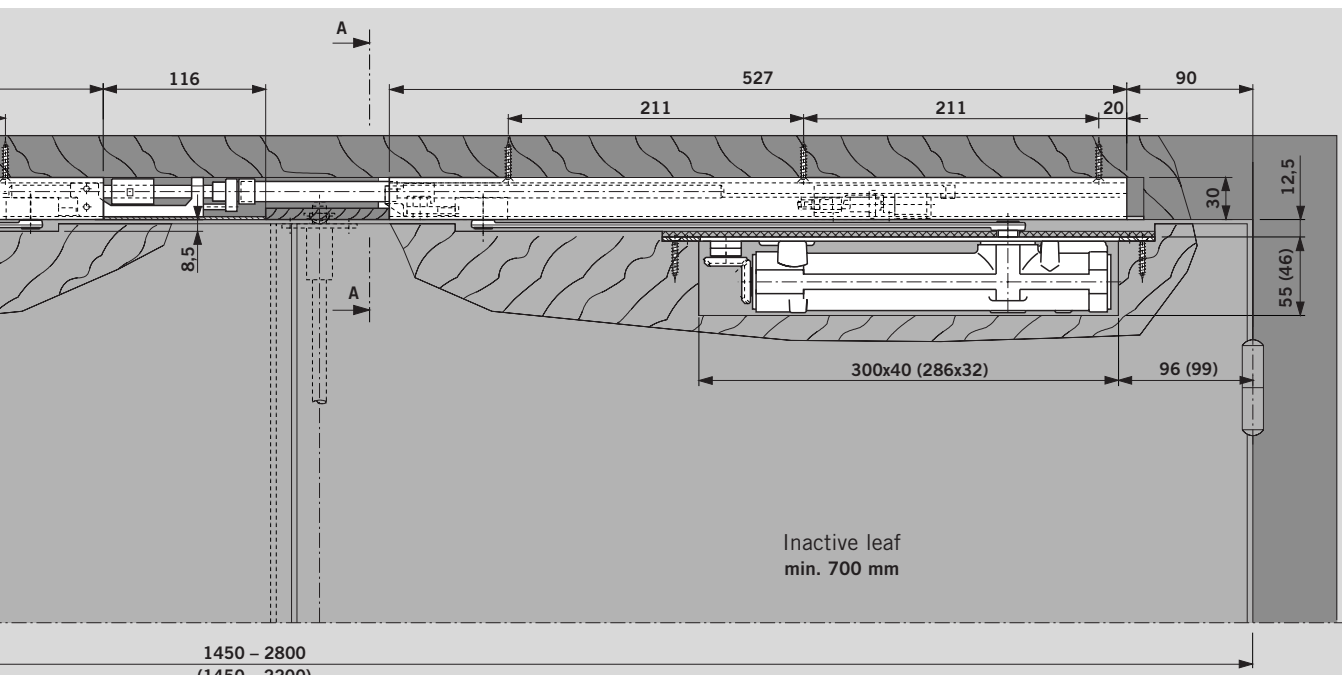

GSR door co-ordinator for
narrow inactive leaf
(inactive leaf slide channel
shortened, arm 260 mm)
Inactive leaf 540 - 700 mm
Active leaf min. 750 mm

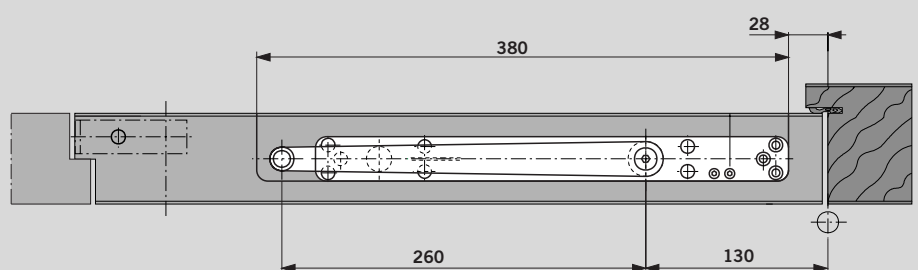
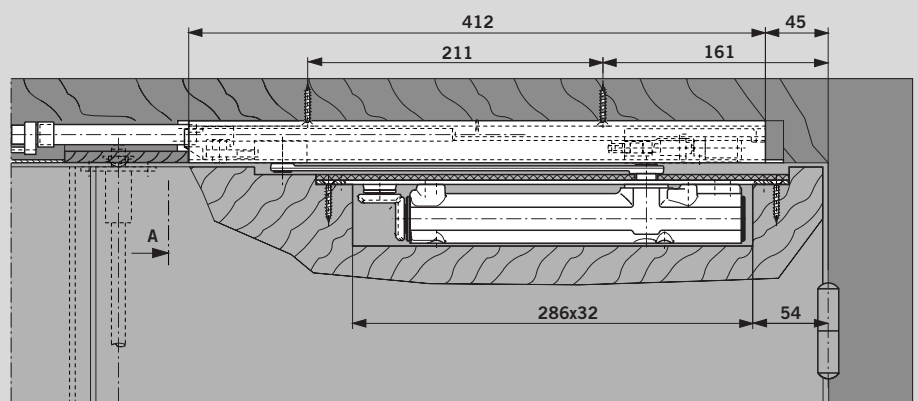

F When installed in fire and smoke check doors, ensure that the DORMA MK 397 carry bar is also fitted.

Installation in an aluminium framed door

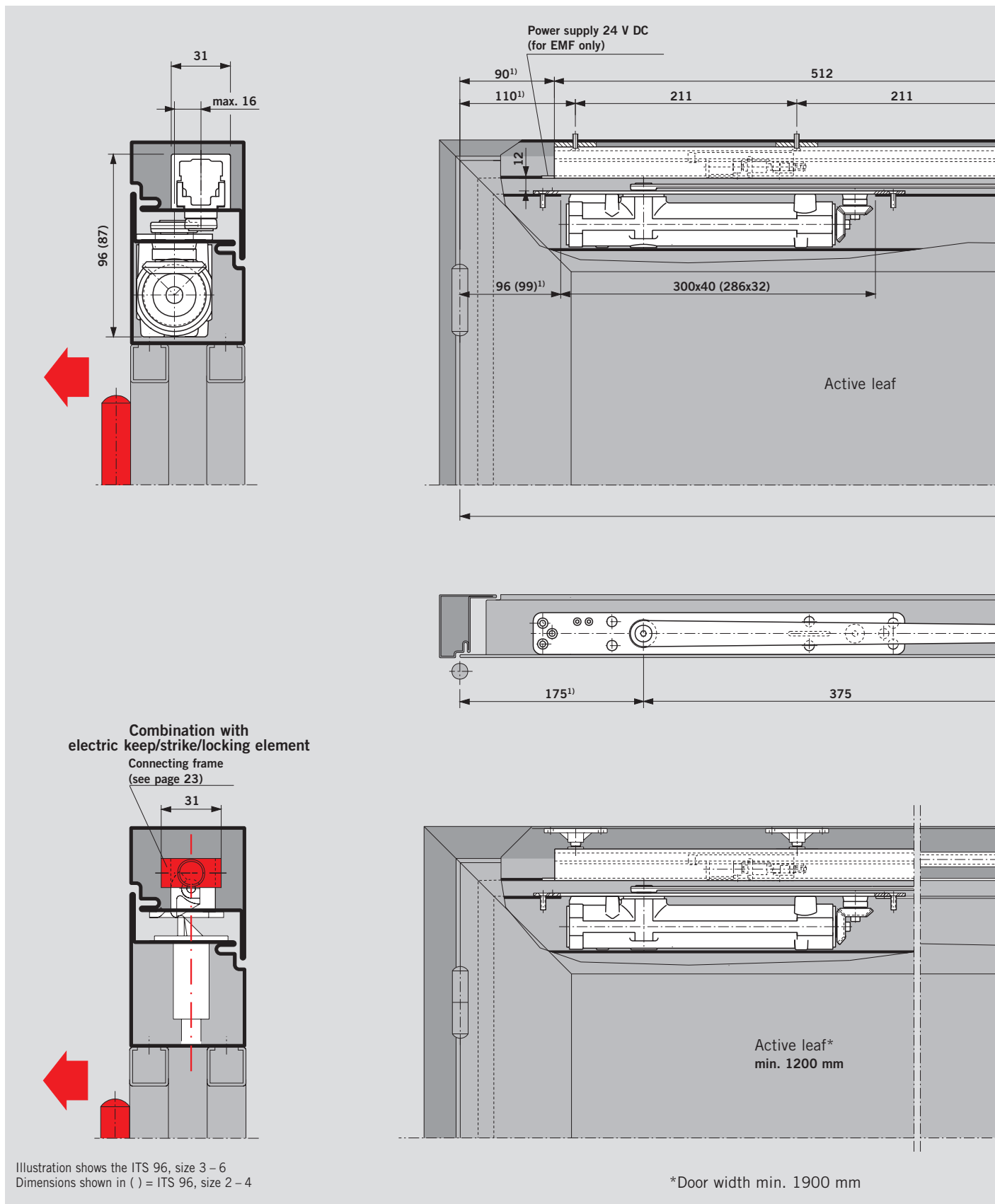

DORMA ITS 96 door closer with DORMA G 96 GSR/GSR-EMF slide channel
Example: Anticlockwise-closing (ISO 6) active leaf; mirror image applies to clockwise-closing (ISO 5) active leaf.

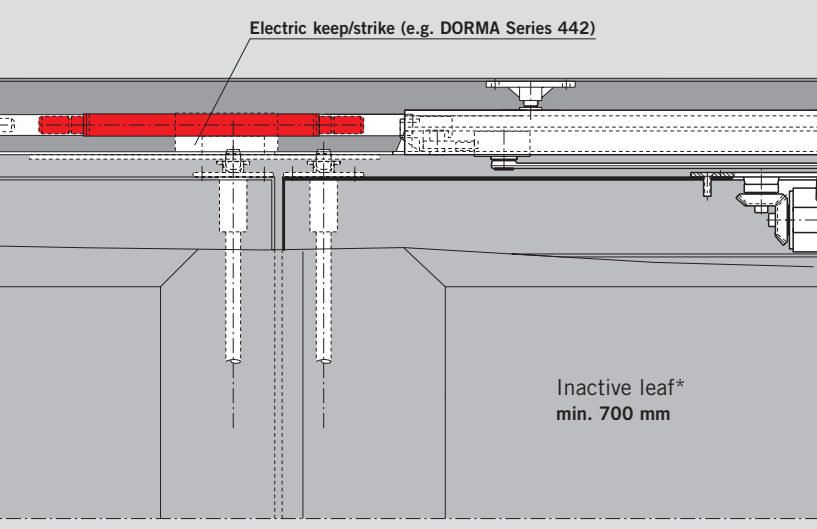
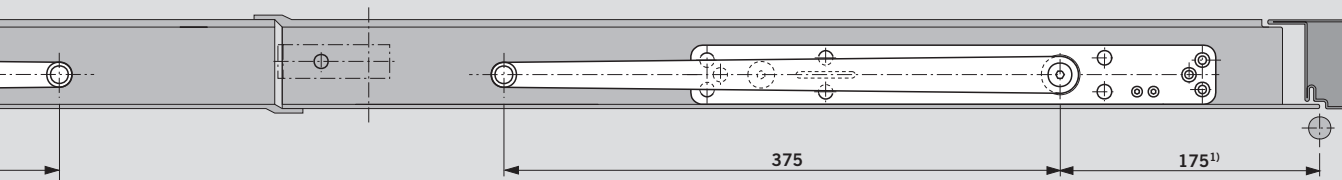
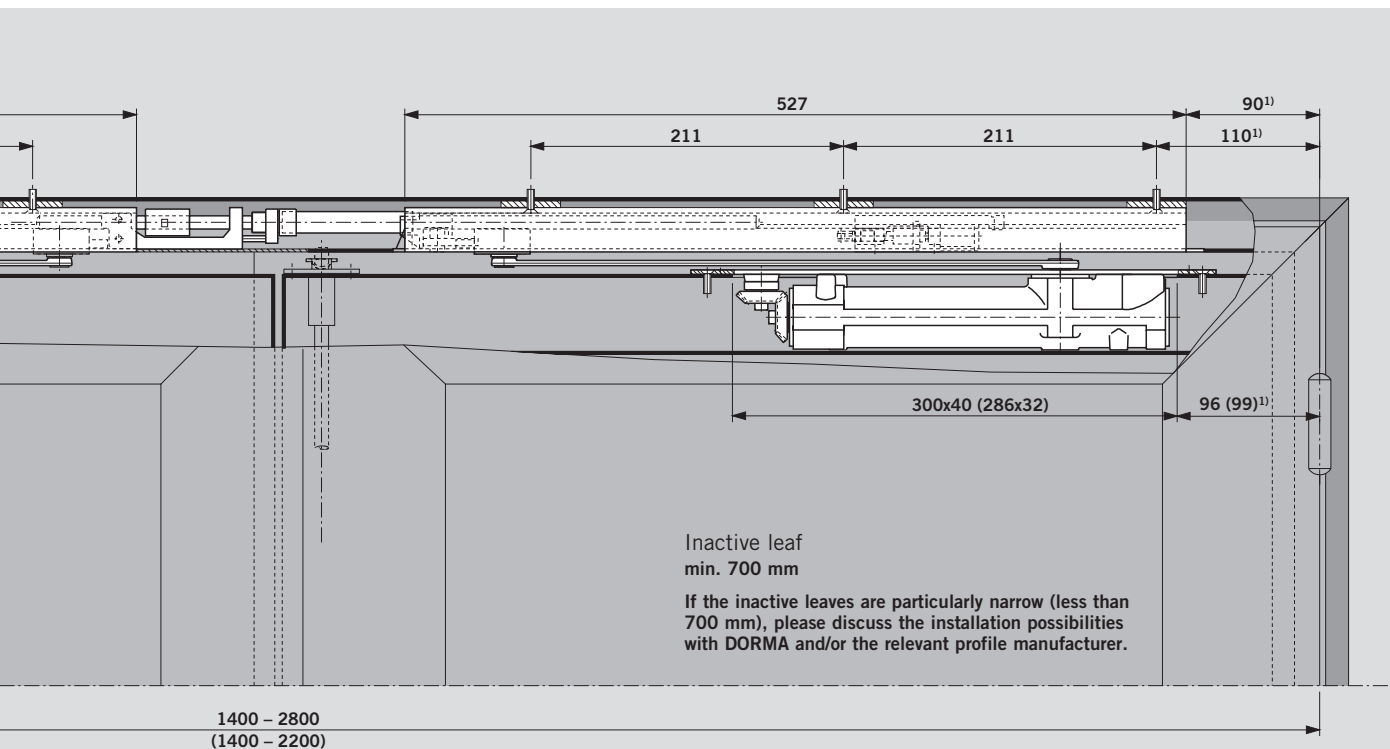

¹⁾ Profile frames with corner angle reinforcement

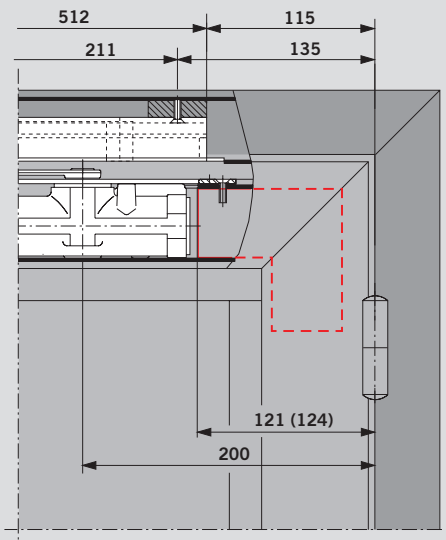

F When installed in fire and smoke check doors, ensure that the DORMA MK 397 carry bar is also fitted.

The DORMA RMZ and DORMA RM smoke detectors provide the ideal complement to the successful, service-proven DORMA ITS 96 range in preventive fire protection environments. They are designed in accordance with the latest

codes issued by the German Institute for Building Technology and ensure perfect interaction between all the devices employed for holding open fire and smoke check doors – whatever the situation.

DORMA RMZ

The DORMA RMZ smoke detector provides a 24 V DC supply for all the hold-open devices connected to it. In the event of an alarm or power failure, it de-energises the devices (release function). It has an auto-

matic reset, which can be switched to manual reset if required. A floating (volt-free) change-over contact and connections for further detectors and external manual release devices are also provided.

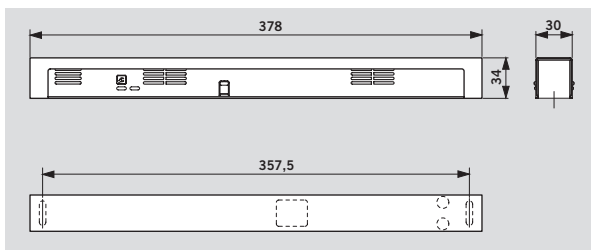

DORMA RM

The DORMA RM smoke detector is designed as a smoke switch and actuates a floating (volt-free) change-over contact in the event of an alarm or power failure. It is also suitable as an add-

on smoke detector for the DORMA RMZ. A floating (volt-free) change-over contact and connections for further detectors and external manual release devices are also provided.

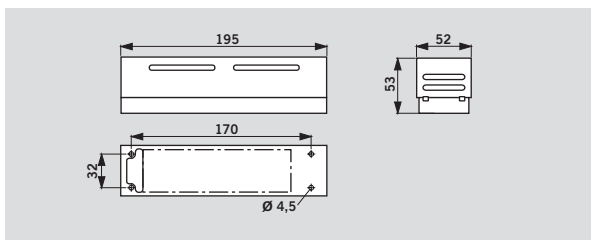

Data and features		RMZ	RM
Functions	Smoke detector Release device Power supply unit	● ● ●	● ● –
Smoke detection	Scattered light principle (optical sensor)	●	●
Fixing	Frame-mounted Ceiling-mounted	● –	– ●
Connection of other detectors	2-wire smoke switches	– ●	● ●
Total installed load (max.) for hold-open device and other detectors in W		9,8	Depends on power supply unit
Power input of internal detectors in W		1,2	0,6
LED indicators	Alarm Standby Maintenance due Contaminated condition	● ● ● ●	● ● – –
Input voltage		230 V AC ± 10 %	24 V DC +15%, -10%
Output voltage		24 V DC	24 V DC
Detector operating voltage		24 V DC +15%, -10%	24 V DC
Input current (max.) with external power supply unit, in A		–	2
Current input (max.) in mA		75	25
Floating (volt-free) change-over contact Safety extra-low voltage (SELV)		24 V AC	24 V AC
Reset	automatic can be changed to manual reset	● ●	● ●
Function checking	Smoke extraction opening test	● –	● ●
Connection terminals for external manual release		●	●
Degree of protection		IP 30	IP 20
Ambient temperature in °C		–20, +40	–20, +50
Weight in kg		0,25	0,40
Dimensions in mm	Length Overall depth Height	379 34 30	195 52 53

● yes – no

Specification texts

RMZ
Smoke detector, Contur design, with standby and maintenance indicators, integral power pack and optical smoke sensor for transom/lintel fixing. For activation of DORMA hold-open devices. A floating (volt-free) alarm contact and connections for further detectors and external manual release devices are provided. Can be switched to manual reset. One-piece cover. Overall height 30 mm. Power supply 230 V AC, operating voltage 24 V DC

Approved by the German Institute for Building Technology, Berlin, for use in a hold-open system. Acceptance inspection of the system is mandatory.

- Colour**
- silver
 - white, sim. to RAL 9010 9016
 - stainless steel
 - polished brass
 - special colour (sim. to RAL)

Make
DORMA RMZ

RM
Universal, non-directional optical smoke detector, 24 V DC, for transom, lintel and ceiling fixing. For use as a smoke switch and monitoring unit for hold-open devices. A floating (volt-free) alarm contact and connections for external manual release device are provided. Approved by the German Institute for Building Technology, Berlin, for use in a hold-open system, and approved by the VdS, Cologne, to EN 54, Part

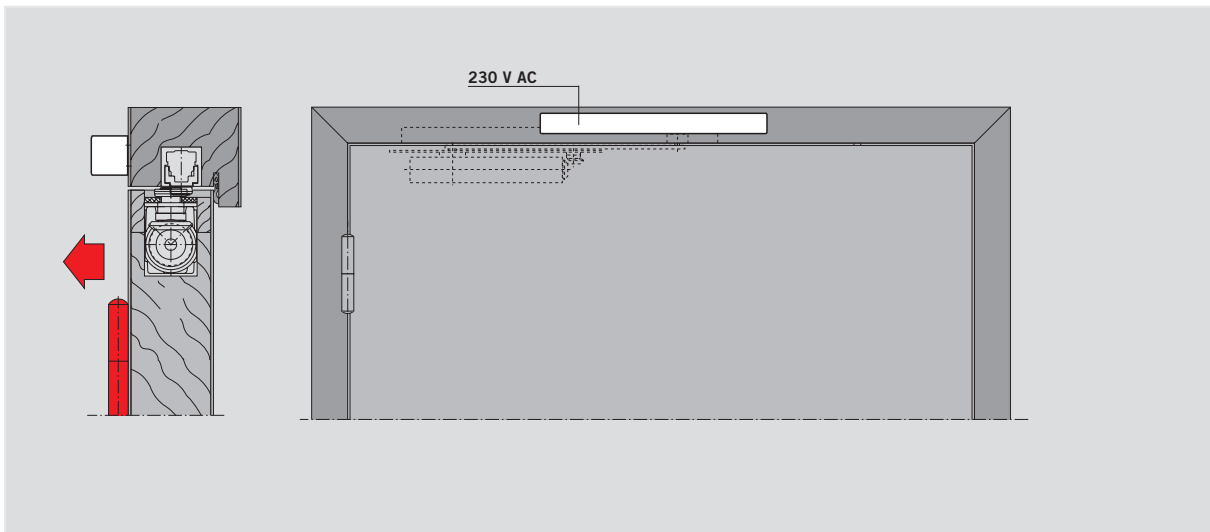

RMZ frame-mounted smoke detector on the pull side connected to an ITS 96 EMF
 Example: Anticlockwise-closing (ISO 6) door; mirror image applies to clockwise-closing (ISO 5) doors.

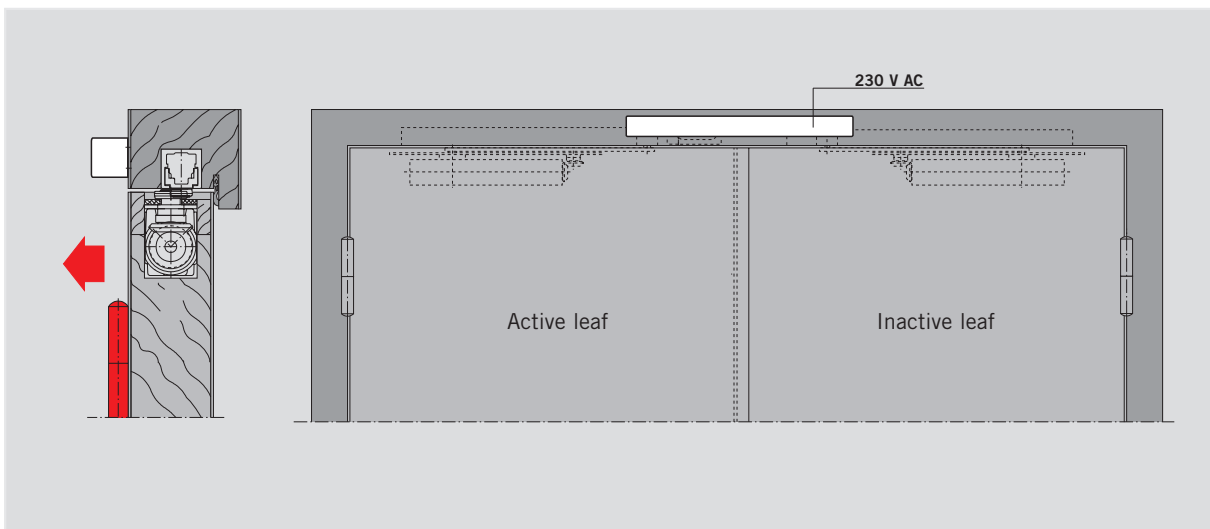

RMZ frame-mounted smoke detector on the pull side connected to an ITS 96 GSR-EMF
 Example: Anticlockwise-closing (ISO 6) active leaf; mirror image applies to clockwise-closing (ISO 5) active leaf.

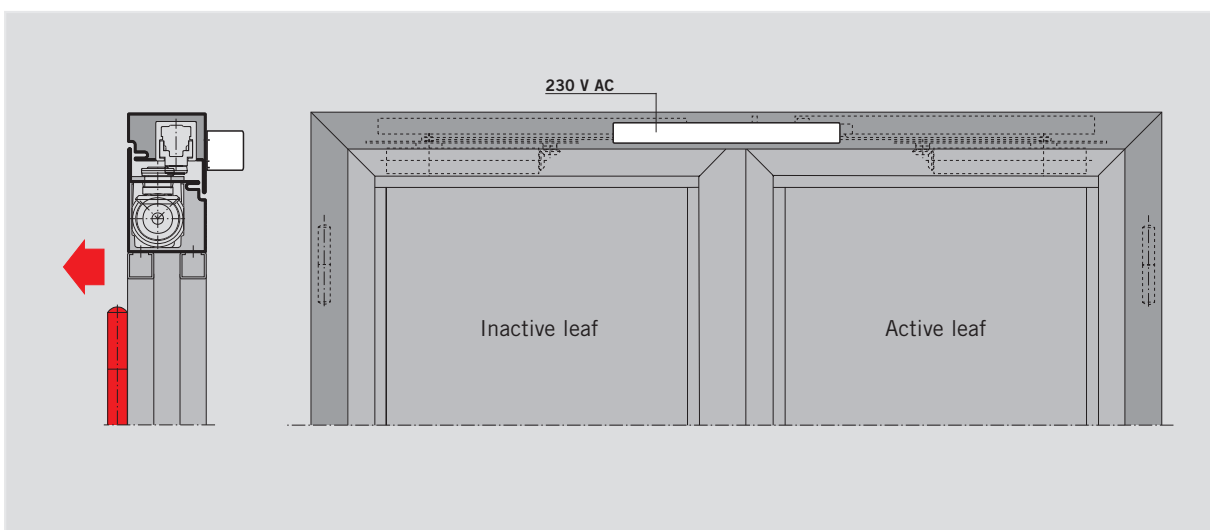

RMZ frame-mounted smoke detector on the push side connected to an ITS 96 GSR-EMF
 Example: Anticlockwise-closing (ISO 6) active leaf; mirror image applies to clockwise-closing (ISO 5) active leaf.

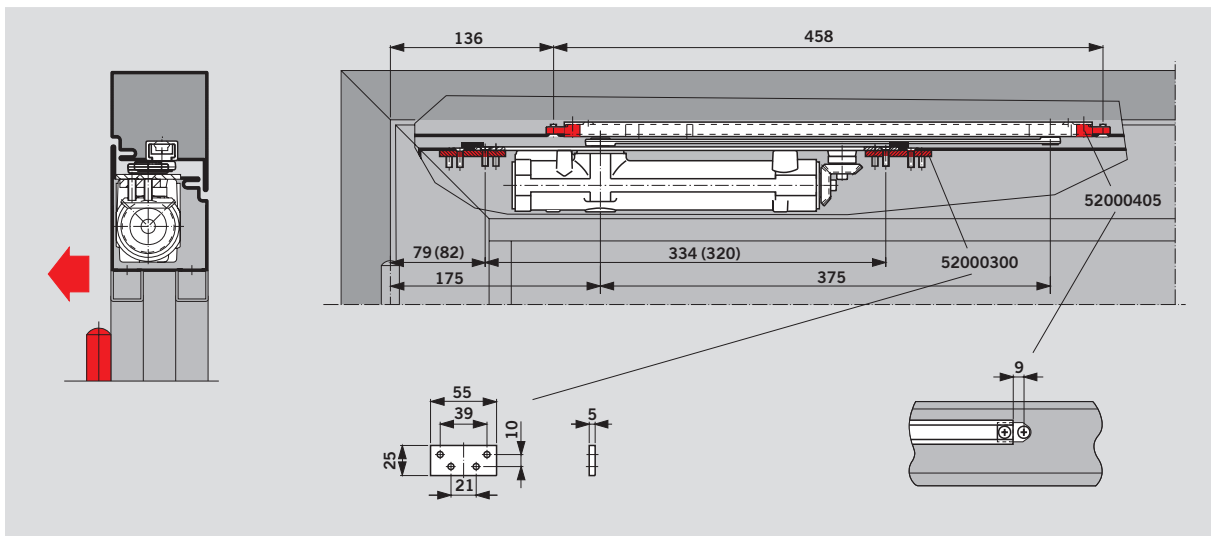

Fixings for **G 96 N20** and mounting plate for ITS 96

Example: Anticlockwise-closing (ISO 6) door; mirror image applies to clockwise-closing (ISO 5) doors.

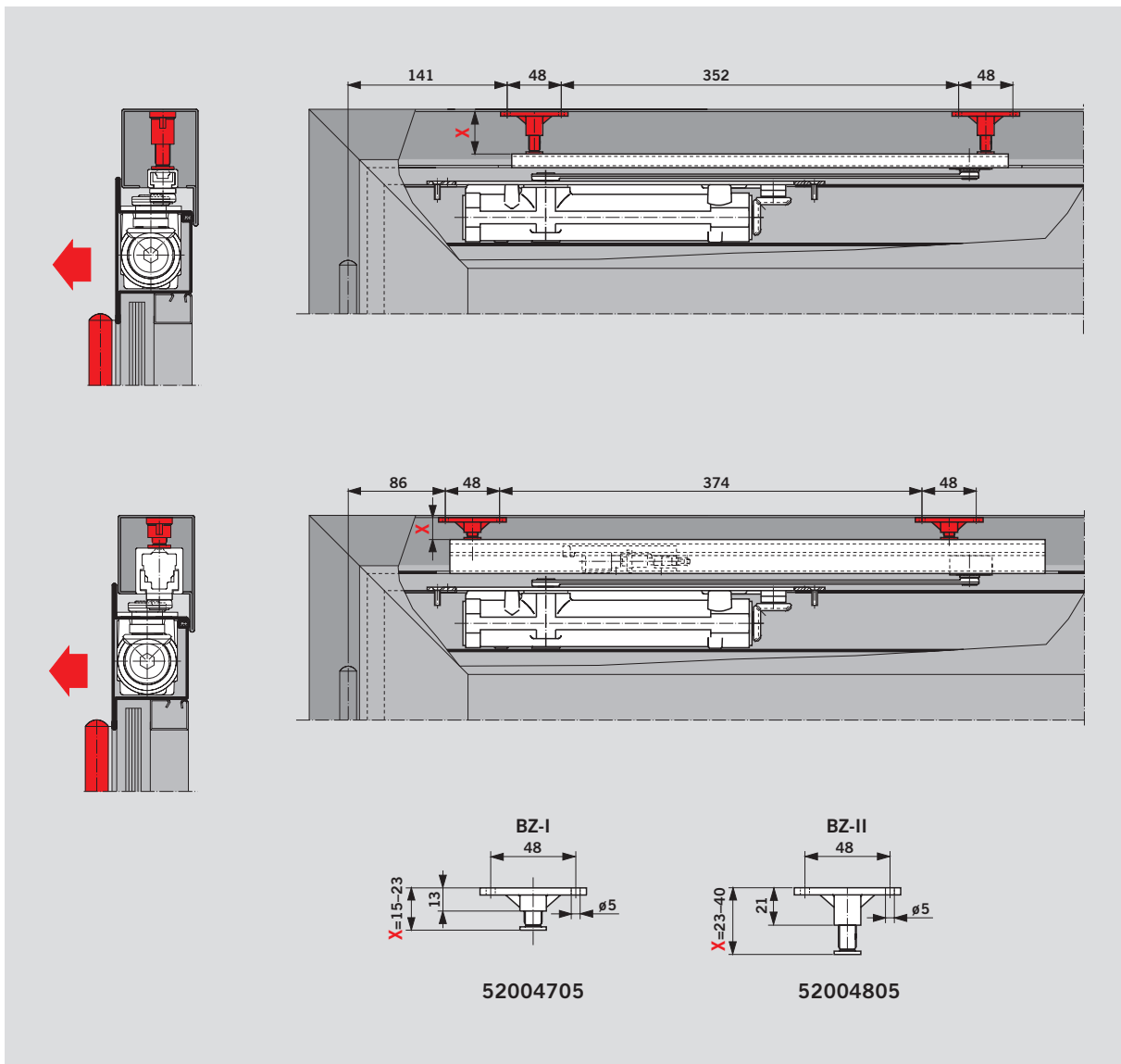

Fixings for height adjustment in relation to **G 96 N20, EMF, GSR**

Example: Anticlockwise-closing (ISO 6) door; mirror image applies to clockwise-closing (ISO 5) doors.

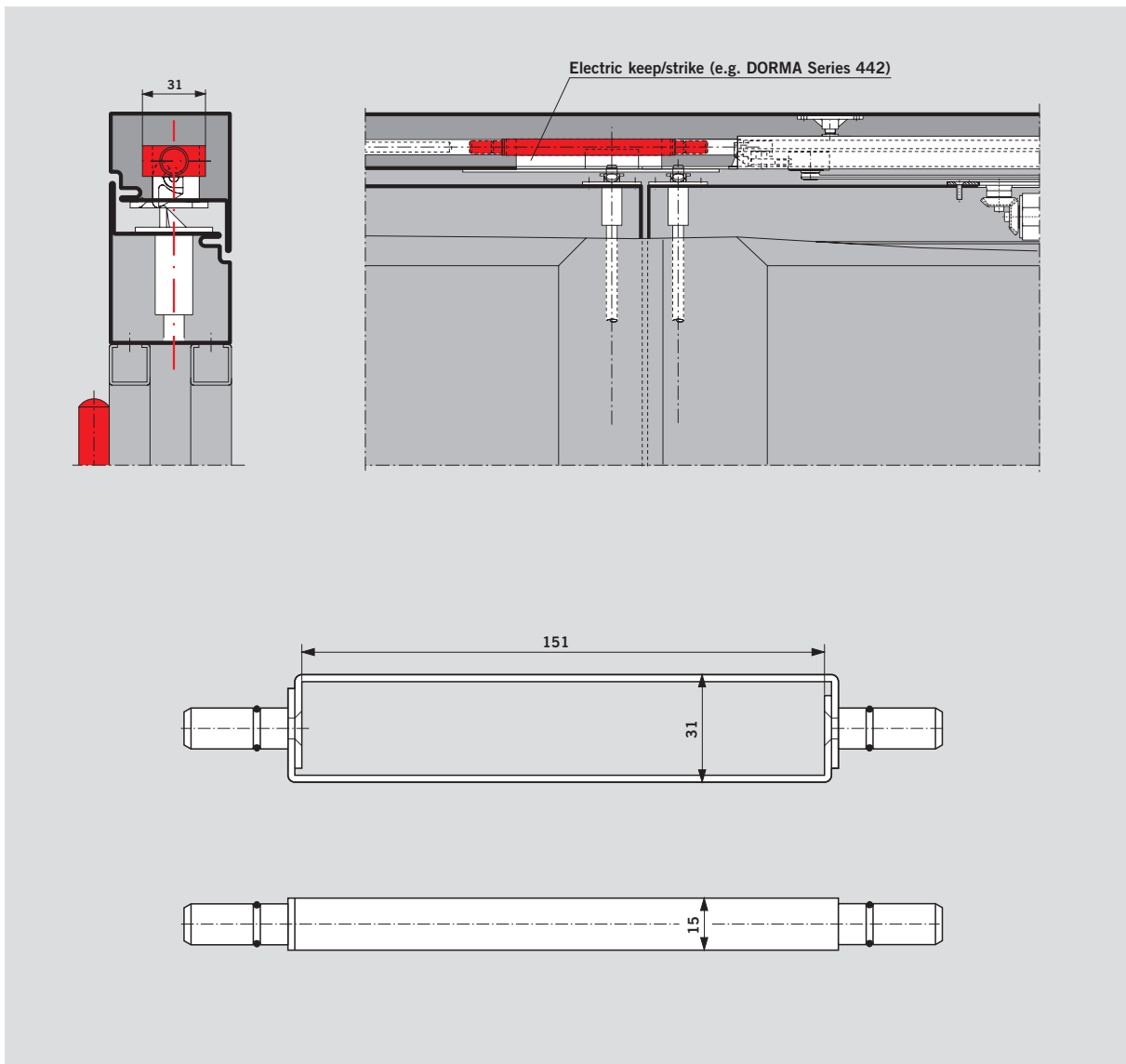

Connecting frame for **G 96 GSR** door co-ordinator for use on doors with electric keep/strike or overhead electromechanical locking element (see page 18)

*Door width min. 1900 mm

If the DORMA G 96 GSR door co-ordinators are required to operate independently of the ITS 96 door closers, e.g. in combination with the ED 200 automatic swing door operator, the connection between the door co-ordinator and the door leaf is provided by means of GSR pivot blocks.

Specification text

Pivot bearing for closer-independent door co-ordination with DORMA G 96 GSR door co-ordinators.

Make
DORMA ITS GSR pivot block

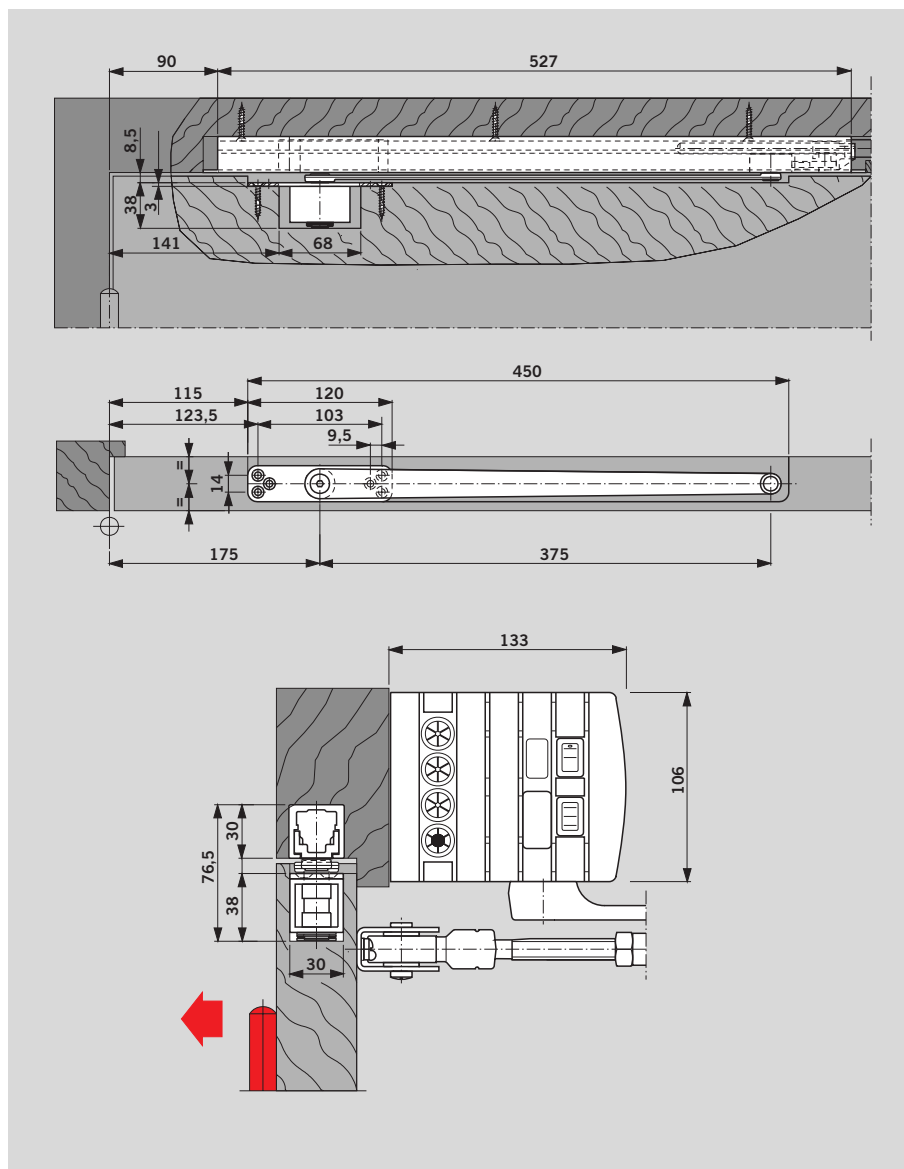

The pivot bearing used in conjunction with the G 96 N20 slide channel also acts as a **cushioned limit stay**.

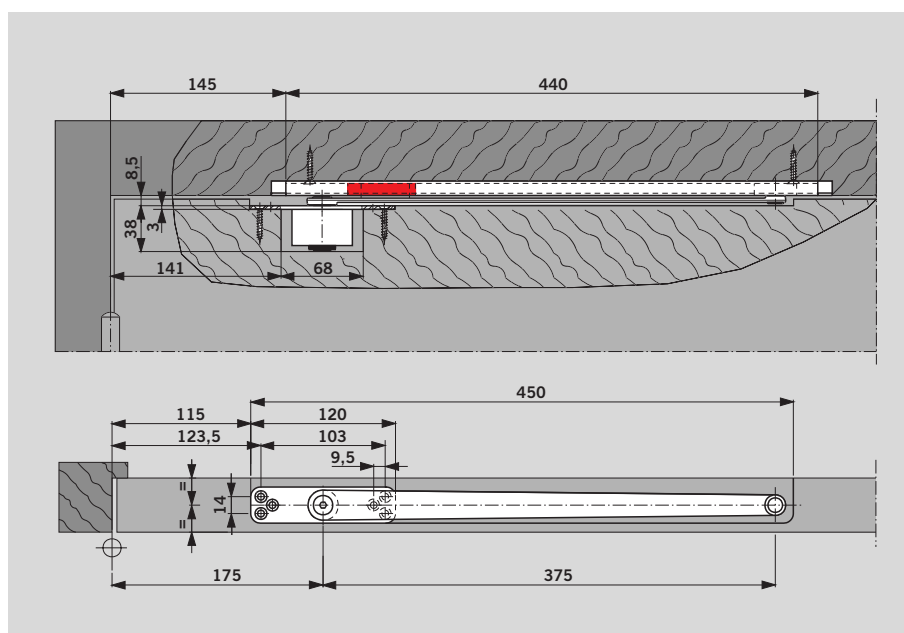

The use of hold-open devices may be subject to certain conditions. These usually deal particularly with the relevant acceptance, routine inspection and maintenance requirements.

The information given on this page is designed to inform all relevant persons of the most important measures to be implemented in order to ensure best practice governing the operation of hold-open systems.

Further details can be found in the following documents:

- Guidelines for hold-open systems, published by the German Institute for Building Technology, Berlin.
- Building Regulations, England and Wales
- Other national building regulations
- general building regulations approval of the hold-open system concerned
- EN 1155

1 General

1.1 In respect of doors etc. which are held open by hold-open systems, the area needed for closure must be kept permanently free of obstructions. This area should be clearly indicated by means of lettering, floor markings or similar. If necessary, structural measures may need to be

taken in order to ensure that wiring/ducting, stored goods or structural components (e.g. false ceilings or other components) do not fall down into the area to be kept clear.

1.2 As far as possible, smoke detectors should be used for hold-open systems.

Smoke detectors should be used for hold-open systems for doors etc. in emergency exits and escape routes.

1.3 All hold-open devices should allow manual release without their operational readiness being adversely affected. Door closers with electro-magnetic hold-open

systems can be released by pressing lightly on the door leaf. If hold-open magnets or free-swing door closers are used, the release function is triggered by pressing a switch. The switch must be located in the immediate proximity of the door and must not be covered when the door is held open.

2 Commissioning

2.1 After the system has been fitted ready for use on site, it should be commissioned to check that its operation is problem-free and that its installation complies with all relevant regulations. The commissioning should only be performed by qualified technical personnel.



3 Routine Inspection

3.1 The operator should keep the hold-open system in a permanently fit state for use and must inspect it at least once a month to ensure its functional integrity.

3.2 In addition, it is the responsibility of the operator to ensure that all devices are checked and maintained/serviced to ensure their combined functional integrity, this to be performed at least

once a year, unless a shorter time period is stipulated in the national regulations. This inspection and servicing activity should only be carried out by a specialist or suitably qualified person.
3.3 The scope, result and

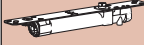
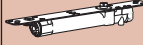
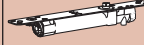
time of the routine inspections should be recorded, and these records should be retained by the operator.

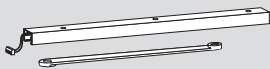
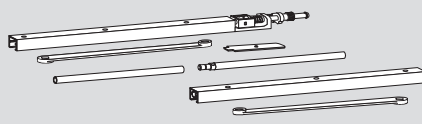
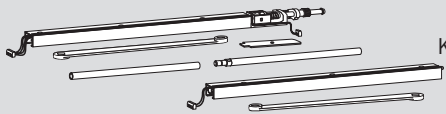
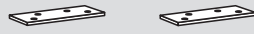
	ITS 96	ITS 96 with 4 mm extended spindle	ITS 96 with 8 mm extended spindle
	 EN 2 – 4 ■ 52400150 EN 3 – 6 ■ 52250150	 EN 2 – 4 ■ 52410150 EN 3 – 6 ■ 52260150	 EN 2 – 4 ■ 52420150 EN 3 – 6 ■ 52270150
For specification text/product description, see page	4	4	4
G 96 N20  L □ 52003701 K8/K12 R □ 52003801	8		
G 96 EMF  L □ 52001501 K8/K12 R □ 52001601	10		
G 96 GSR  □ 52001801 K8/K12 260 ¹⁾ □ 52004001	12	2x	2x
G 96 GSR-EMF  □ 52001701 K8/K12 260 ¹⁾ □ 52004201	14	2x	2x
Fixing plates for ITS 96  52000300	22	#	#

■ = Closer body separate







□ = Slide channel separate

= Optional accessory

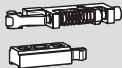
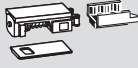
L =  LH/anticlockwise closing (ISO 6)

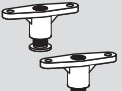
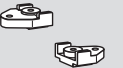
R =  RH-clockwise closing (ISO 5)

¹⁾ GSR door co-ordinator for inactive leaf of 540–700 mm (inactive leaf slide channel shortened, arm 260 mm)

RF hold-open unit for G 96 N	RF hold-open unit for G 96 GSR, inactive leaf	Fixing BZ I for narrow-stile/alu-framed doors	Fixing BZ II for narrow-stile/alu-framed doors	Fixings for mounting the G 96 N20 aluminium doors	Connecting frame for G 96 GSR	Pivot bearing	Carry bar MK 397
 K8/K12 52005600	 K8/K12 52003500	 52004705	 52004805	 52000405	 52004400	 52003400 ¹⁾	 470029xx ²⁾
8	–	22	22	22	23	24	
#		#	#	#		#	
#		#	#	#		#	
		#	#				
		#	#				
	#	#	#		#	#	#
	#	#	#		#	#	#
		#	#		#		#
		#	#		#		#

Smoke detector system

RMZ
64800xx

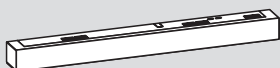

RM
648200xx



Colour	xx		
silver	01	Stainless steel	
white (RAL 9016)	11	“Design” finish	04
white (RAL 9010)	10	polished brass	05
Special colour	09		

For specification text/product description, see page 20

¹⁾ Pivot bearing with 4 mm and 8 mm extended spindle available on request

²⁾ MK 397 Colour xx
galvanised 00
special colour 30



Door Control



Automatic



**Glass Fittings
and Accessories**



**Security/Time
and Access (STA)**



Movable Walls

Door Control Division worldwide

Central Europe

DORMA GmbH + Co. KG
DORMA Platz 1
D-58256 Ennepetal
Tel. +49 2333 793-0
Fax +49 2333 793-495

Australasia

DORMA Door Controls Pty. Ltd.
46-52, Abbott Road
Hallam/Victoria 3803
Australia
Tel. +61 3979 63555
Fax +61 3979 63955

China/Hong Kong

DORMA Door Controls
(Suzhou) Co. Ltd.
No. 9, Hong Feng Road
Suzhou Singapore Industrial Park
Suzhou, 215021
P.R. of China
Tel. +86 512 67612481
Fax +86 512 67614582

Emerging Markets

DORMA GmbH + Co. KG
DORMA Platz 1
D-58256 Ennepetal
Tel. +49 2333 793-0
Fax +49 2333 793-495

Far East

DORMA Far East Pte. Ltd.
No. 31 Gul Lane
Singapore 629425
Tel. +65 6268 7633
Fax +65 6265 7995

France

DORMA France S.A.S.
Europarc
42, rue Eugène Dupuis
F-94046 Créteil
Tel. +33 1 41942400
Fax +33 1 41942401

Gulf

DORMA Gulf Door Controls FZE
Jebel Ali Free Zone South
Plot No. S 20135
Road No. SW 301 G
P.O. Box 17268
Dubai – United Arab Emirates
Tel. +971 4 8020400
Fax +971 4 8869100 / 8869101

North America

DORMA Architectural Hardware
DORMA Drive, Drawer AC
Reamstown, PA 17567-0411
Tel. +1 800 5238483
Fax +1 800 2749724

North America

DORMA Architectural Hardware
DORMA Drive, Drawer AC
Reamstown, PA 17567-0411
Tel. +1 800 5238483
Fax +1 800 2749724

North America

DORMA Architectural Hardware
DORMA Drive, Drawer AC
Reamstown, PA 17567-0411
Tel. +1 800 5238483
Fax +1 800 2749724

Scanbalt

DORMA Sverige AB
F O Petersons Gata 24
SE-421 31 Västra Frölunda
Tel. +46 31 289520
Fax +46 31 281739

South America

DORMA Sistemas de Controles
para Portas Ltda.
Av. Piracema, 1400
Centro Empresarial Tambore
CEP 06400-933 Barueri/
São Paulo, Brasil
Tel. +55 11 46899280
Fax +55 11 46899215

South-East Europe

DORMA AUSTRIA GmbH
Pebering Strass 22
A-5301 Eugendorf
Tel. +43 6225 284880
Fax +43 6225 28491

South Europe

DORMA Italiana S.r.l.
Via. Canova 44/46
I-20035 Lissone (MI)
Tel. +39 039 244031
Fax +39 039 24403310

Spain

DORMA Ibérica, S.A.
Camino San Martin de la Vega, 4
E-28500 Arganda del Rey
(Madrid)
Tel. +34 91 8757850
Fax +34 91 8757881

UK/Ireland

DORMA UK Ltd.
Wilbury Way
Hitchin
GB-Hertfordshire SG4 0AB
Great Britain
Tel. +44 1462 477600
Fax +44 1462 477601